

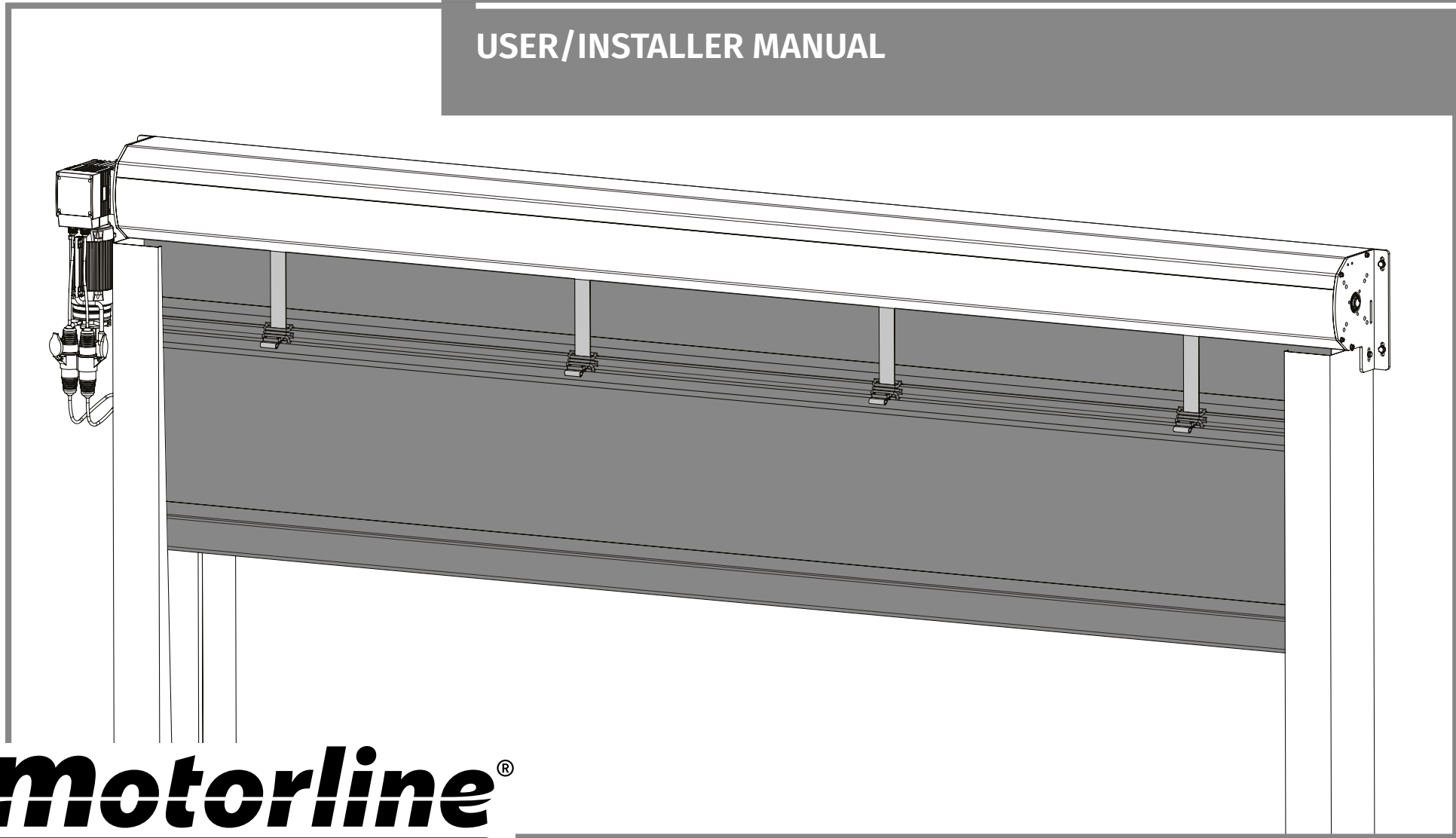

INDUSTRIAL STACKING DOOR

USER/INSTALLER MANUAL



motorline[®]
PROFESSIONAL

00. CONTENT

INDEX

01. SAFETY INSTRUCTIONS	
STANDARDS TO FOLLOW	1B
02. THE AUTOMATION	
COMPONENTS	2
TECHNICAL CHARACTERISTICS	3A
03. PRE-INSTALLATION	
RECOMMENDATIONS	3B
DIMENSIONS	4
MANUAL OPENING/CLOSING	5A
04. INSTALLATION	
FIXING THE SAFE PROFILE	5B
FIXING THE LATERAL GUIDES	6B
FIXING THE MANEUVERS BOARD	7A
LIMIT-SWITCHES ADJUSTMENT	7B

01. SAFETY INSTRUCTIONS

STANDARDS TO FOLLOW

ATTENTION:

- It is important for your safety that these instructions are followed. The installation or incorrect use of this product may cause damage and injury.
- Keep these instructions in a safe place for future reference.
- This product was designed and manufactured strictly for the use indicated in this manual. Any other use not expressly indicated may damage the product and / or can cause physical and property damages, and will void the warranty.
- The **ELECTROCELOS S.A.** is not responsible for the improper use of the product, or other use than that for which it was designed.
- The **ELECTROCELOS S.A.** is not responsible if safety standards were not taken into account when installing the equipment, or for any deformation that may occur.
- The **ELECTROCELOS S.A.** is not responsible for insecurity and malfunction of the product when used with components that were not sold by the them.
- Do not make any changes to the automation components and / or their accessories..
- Before proceeding with the installation switch off the electric current.
- The installer should inform the customer how to handle the product in an emergency and provide him the manual.
- Keep remote controls away from children, to prevent the automated system from being activated involuntarily.
- The customer shall not, under any circumstances, attempt to repair or tune the automatism. Must call qualified technician only.
- Connect the automation to a 230V , with ground wire.

02. THE AUTOMATION

COMPONENTS

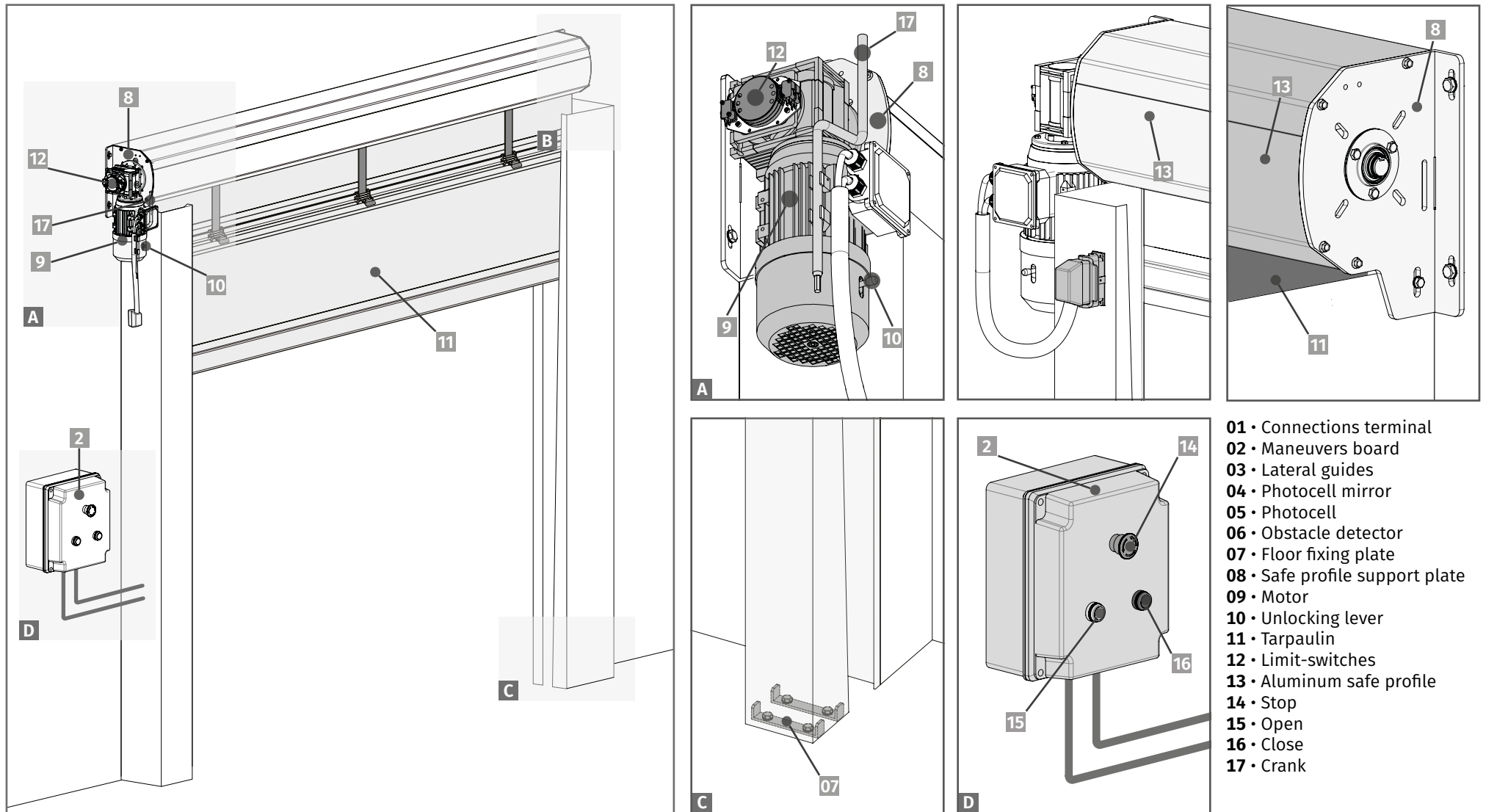

02. THE AUTOMATISM

TECHNICAL CHARACTERISTICS

The Industrial Stacking Door are built in white lacquered aluminum profiles. They have between 3 and 6 have reinforcing crossbars, according to the size of the door, suitable for areas with medium pressure air.

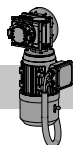

MOTOR	Span <=35m ²	Span > 35m ²
• Power Supply	230V (three-phase)	230V (three-phase)
• Frequency	50Hz	50Hz
• Potency	1100W	1500W
• Current	2,50A	3,3A
• RPM	140RPM	140RPM
• Noise	<60dB	<60dB
• Force	5Nm	10,1Nm
• Working Temperature	-30°C to 70°C	-30°C to 70°C
• Protection Grade	IP54	IP54
• Working Frequency	Intensive	Intensive
• Isolation Class	Class F	Class F



TARPAULIN	
• Wire	1100 dtex PES HT
• Weight	670g/m ²
• Tensile strength	2800N/5cm
• Tear resistance	300N
• Adherence	90N/5cm
• Finishing	Varnish on both sides
• Operating temperature	-30°C to 70°C

03. PRE-INSTALLATION

RECOMMENDATIONS

To the Industrial Stacking Door work properly, before the installation it is important to take into account the following parameters:

- Read all the steps at least once, in order to learn about the installation and configuration process.
- Check the horizontal ground alignment, so that the door can be mounted properly.
- Make sure there is adequate electrical protection against short circuits/power surges and grounding in Electrical Board.
- Be careful in the event of handling directly the control board. Improper handling can damage some electrical components.
- Make sure you have prepared all the necessary materials for the installation.
- Evaluate the security devices to be installed. This will ensure that unexpected accidents do not happen.
- Use appropriate screws to the place where will be the components of the door.



It is very important that all precautions are respected!
Only in this way it can be assured the proper functioning and durability of the automation!



KIT COMPONENTS

- Three-phase motor from 1100W to 1500W
- MC111PR maneuver board with up, down and stop buttons
- Safety photocells
- Exterior waterproof push-button
- Detection of obstacles
- Variable Speed Drive (incorporated on MC111)



OPTIONAL COMPONENTS (not included in the kit)

- Magnetic coil
- Remote controls
- Radars

REQUIRED FOR INSTALLATION:



03. PRE-INSTALLATION

DIMENSIONS

Doors for passage spans up to **35m²**.

NOTA: Passage spans with a maximum width of 6500mm.

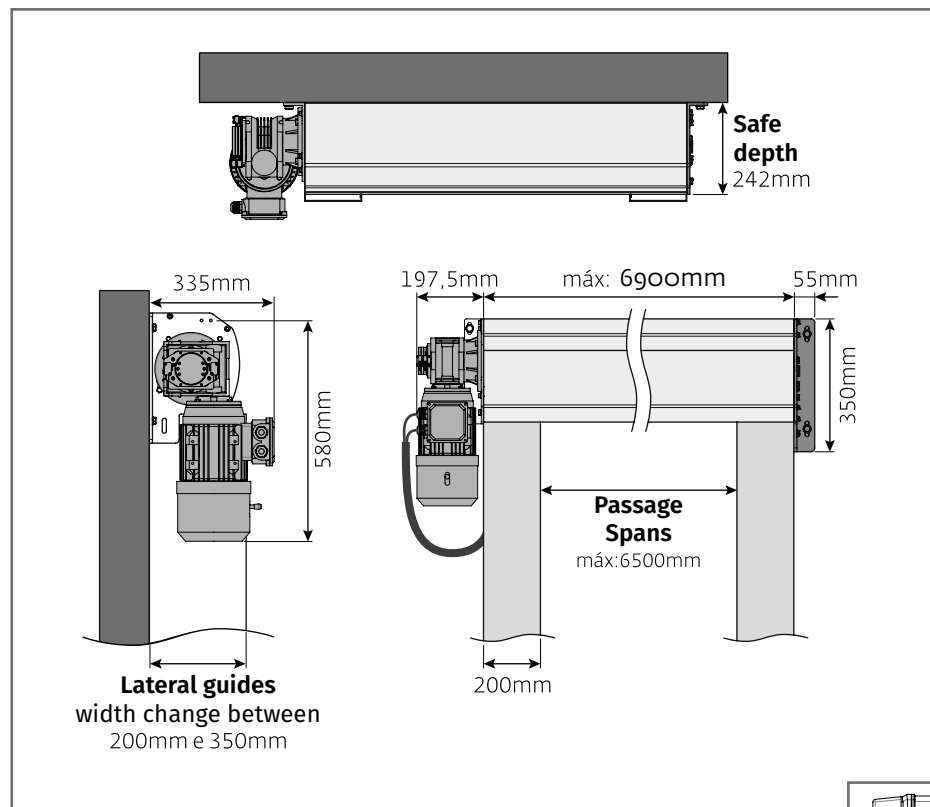

Doors for passage spans with **36m² or superior**.

NOTA: Passage spans with a maximum width of 6500mm.

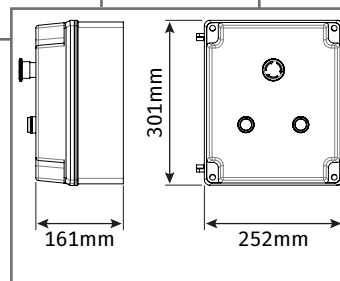
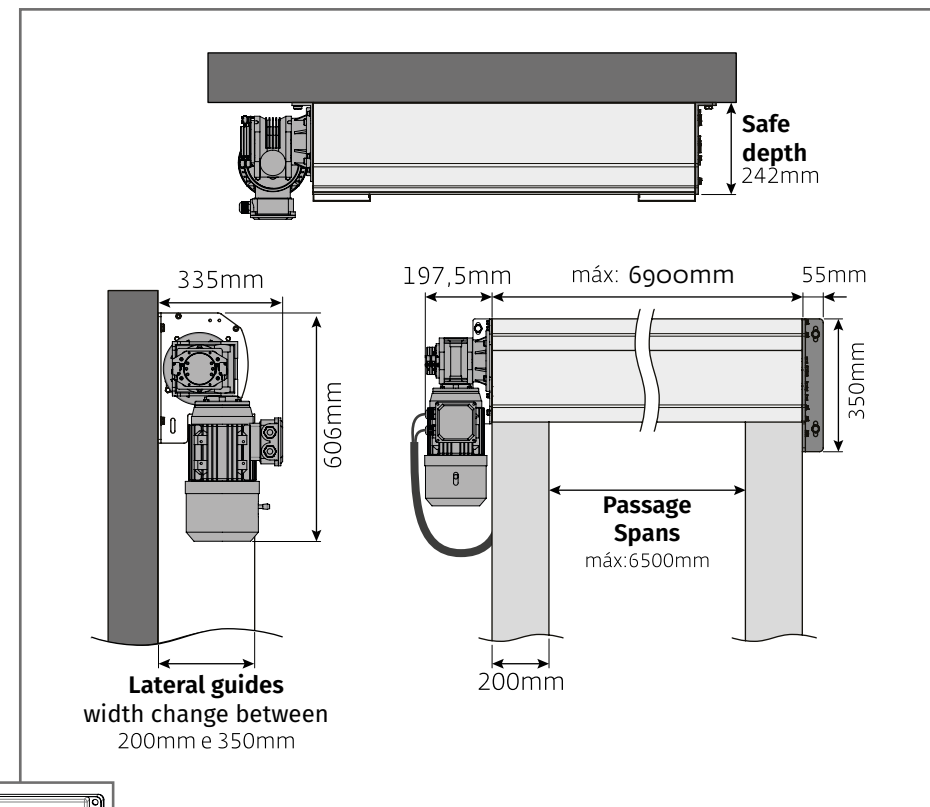

03. PRE-INSTALLATION

MANUAL OPENING/CLOSING

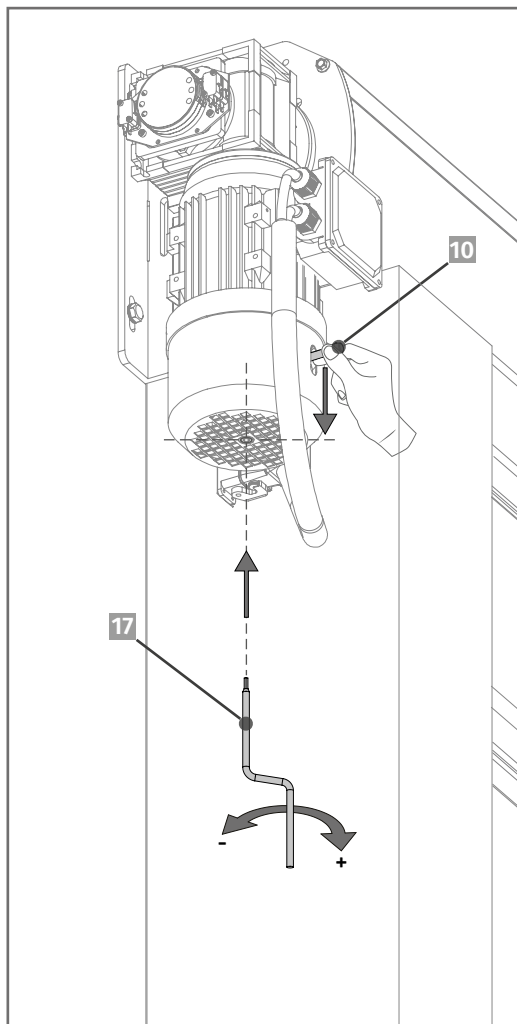

To open or close the door manually, simply push and hold the release lever (10), and use the hexagonal handle 6mm (17) to turn the screw installed in the bottom of the motor, as shown on the image.

- Turning to the right will open the door and turn to the left will close.
- To facilitate the task use an automatic screw machine to quickly rotate the screw.
- For every 10 turns, the door will go up/down for about 250mm.

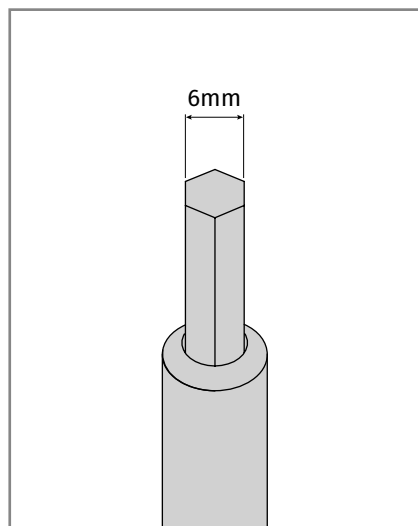

04. INSTALLATION

FIXING THE SAFE PROFILE

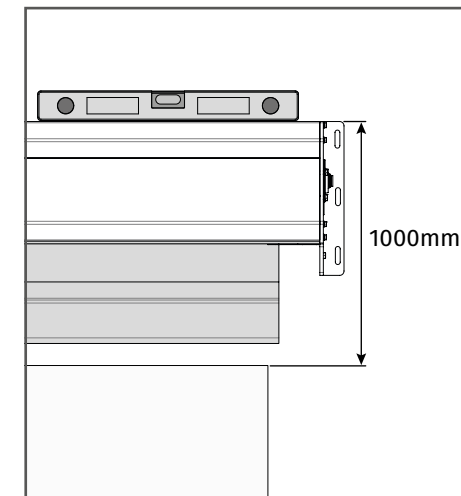
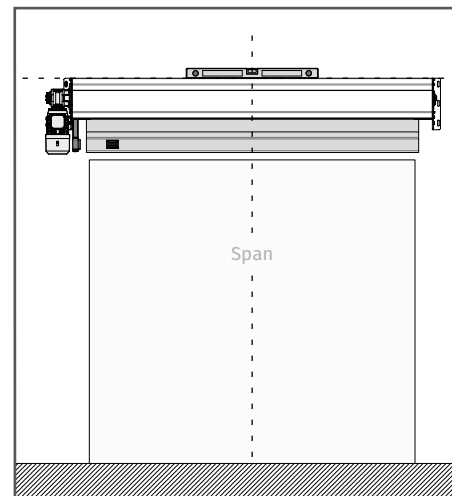

01 • Apply the safe profile on the wall, centered with the passage. Adjust the safe profile position taking into account the size indicated on the image and the horizontal leveling (use a level).

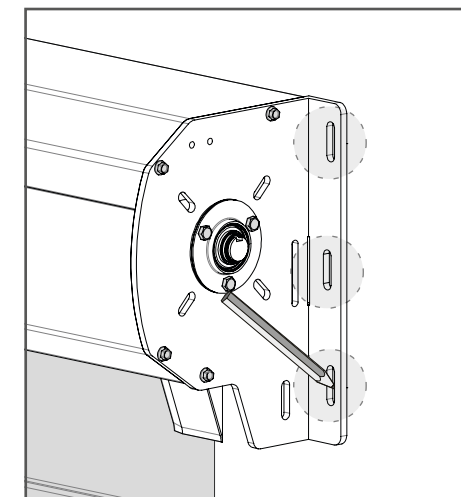
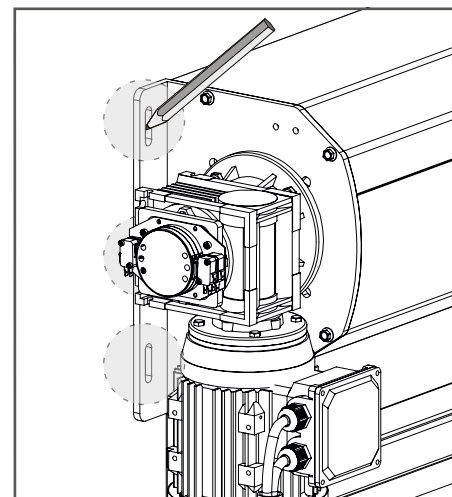

02 • Based on the existing holes in the support plates, mark the locations for drilling.

04. INSTALLATION

FIXING THE SAFE PROFILE

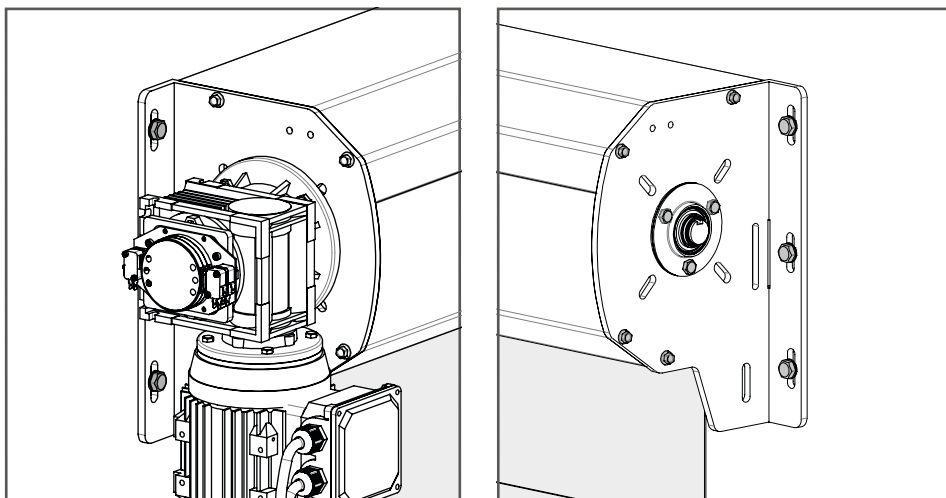
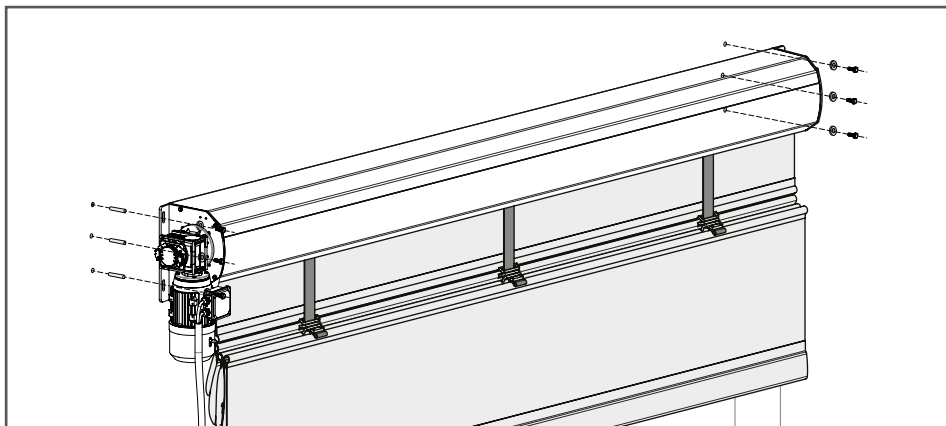

03 • Make holes in the marked locations, and then apply the safe profile on the wall by fixing it with bushings (metallic) and screws.



Make sure the screws are properly tightened to prevent accidents!

04. INSTALLATION

FIXING THE LATERAL GUIDES

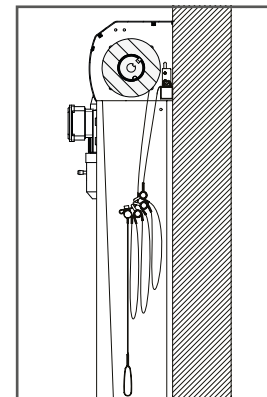
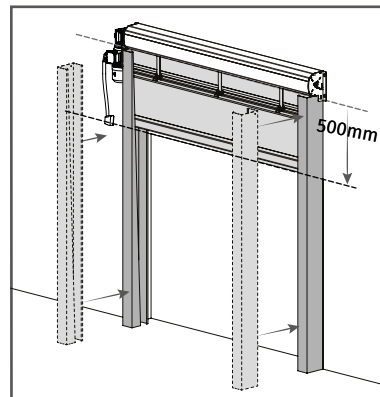

01 • Unlock the motor (see page 5A) and pull the tarpaulin manually 500mm.

02 • Place the lateral guides for the inner side of the safe profile's support plates and against the wall.

03 • The tarpaulin must remain inside the guides, so that it can move up and down always inside of them.

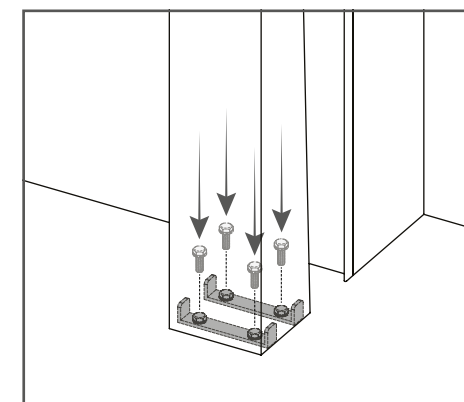
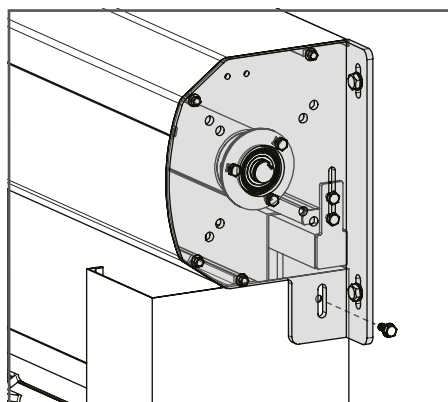

04 • Secure the lateral guides on the safe support plates with screws and washers, squeezing them on the nuts located on the guides.

05 • Secure the lateral guides to the floor using for this purpose the existing plates at the bottom. Start by making holes in the floor taking into account the existing holes in the plates for the application of screws.

Finally, tighten the screws until the guide is properly secure.

04. INSTALLATION

FIXING THE MANEUVERS BOARD

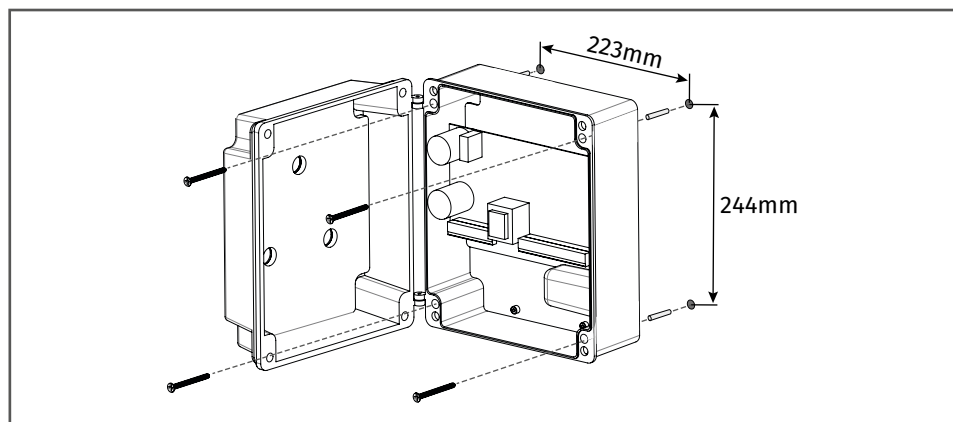

- 01 • Check the a control board drillings (page 4).
- 02 • Make the holes in the wall.
- 03 • Secure the control board on the wall with screws with bushings (screws and bushings not provided in the kit).

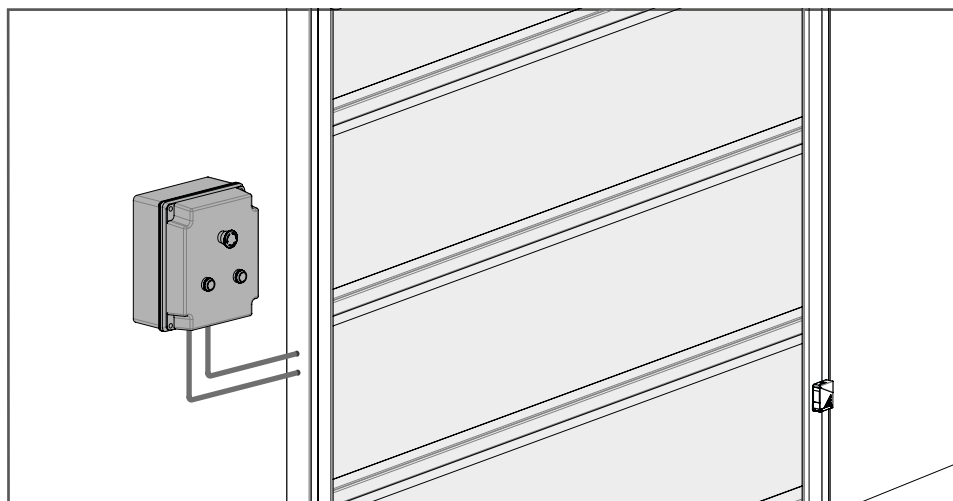

04. INSTALLATION

LIMIT-SWITCHES ADJUSTMENT

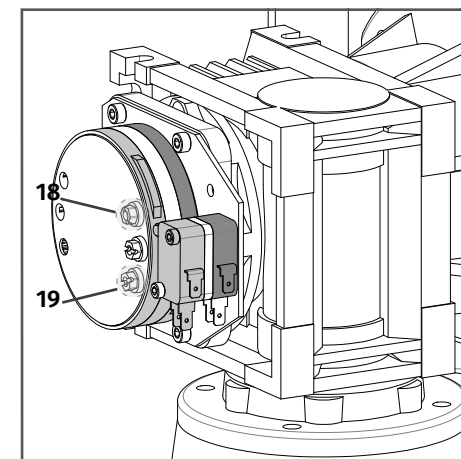
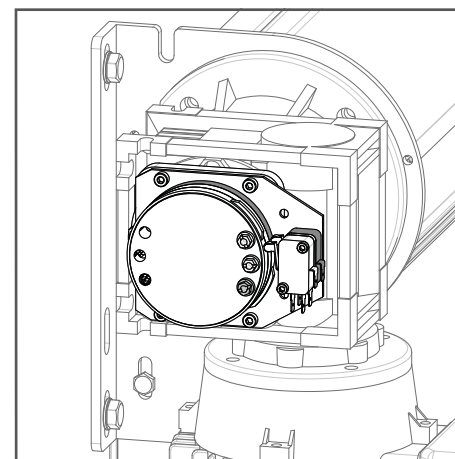

- 01 • Manually place the door in the open position using the handle (5A page).
- 02 • Turn the adjustment screw 18 (red) until the red ring micro-switch activates the corresponding micro-switch.
- 03 • Manually place the door in the closed position using the handle.
- 04 • Turn the adjustment screw 19 (white) until the white ring micro-switch activates the corresponding micro-switch.

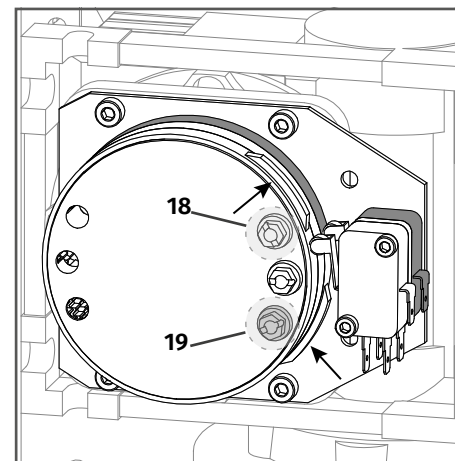

NOTE • The red ring must activate the micro-switch underneath, and white ring must activate the micro-switch on top, as visible in the left image.

Micro's connection

