

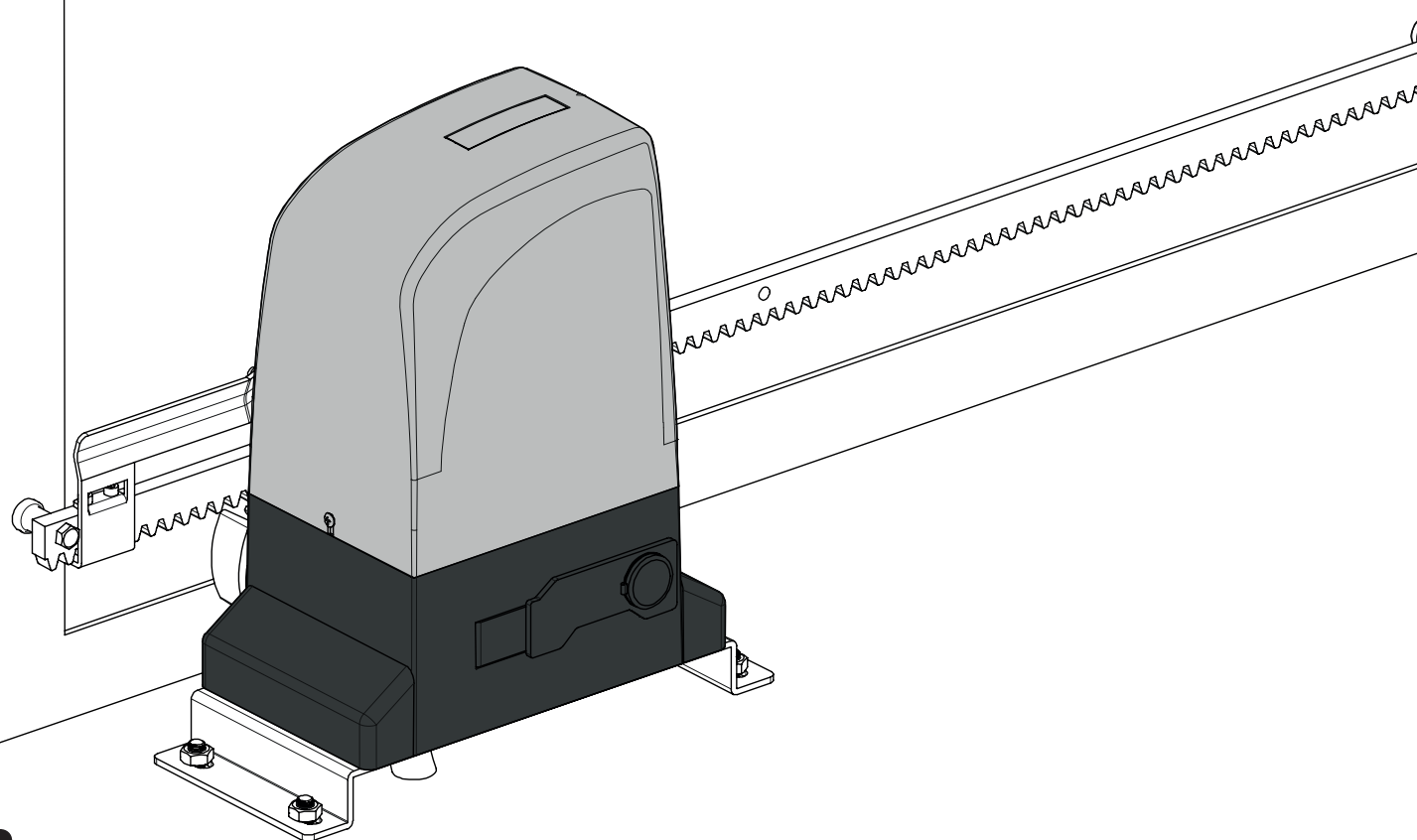

SLIDE & OL

USER'S AND INSTALLER'S MANUAL



motorline[®]
PROFESSIONAL

00. CONTENT





INDEX

01. SAFETY INSTRUCTIONS	
STANDARDS TO FOLLOW	1B
02. OPERATOR	
TECHNICAL SPECIFICATIONS	3A
DESCRIPTION	3A
DIMENSIONS	3B
DESCRIPTION OF THE SYSTEM	3B
ACCESSORIES	4A
INSTALLATION TOOLS	4A
03. INSTALLATION	
PRELIMINARY CHECKS	4A
PREPARING THE FOUNDATION PLATE	4B
POSITIONING THE OPERATOR	4B
FIXING OPERATOR	5A
RELEASING THE OPERATOR	5B
INSTALLING THE RACK	5B
INSTALLING LIMIT SWITCH PLATE	6A
MAINTENANCE AND REPAIRS	6A
CLUTCH ADJUSTMENT	6B
04. CONNECTIONS OF THE MOTOR	
FOR 800A/OL1500	7A
FOR OL2000	7B

01. SAFETY INSTRUCTIONS

STANDARDS TO FOLLOW

ATTENTION:

	This product is certified in accordance with European Community (EC) safety standards.
	This product complies with Directive 2011/65/EU of the European Parliament and of the Council, of 8 June 2011, on the restriction of the use of certain hazardous substances in electrical and electronic equipment.
	(Applicable in countries with recycling systems). This marking on the product or literature indicates that the product and electronic accessories (eg. Charger, USB cable, electronic material, controls, etc.) should not be disposed of as other household waste at the end of its useful life. To avoid possible harm to the environment or human health resulting from the uncontrolled disposal of waste, separate these items from other types of waste and recycle them responsibly to promote the sustainable reuse of material resources. Home users should contact the dealer where they purchased this product or the National Environment Agency for details on where and how they can take these items for environmentally safe recycling. Business users should contact their vendor and check the terms and conditions of the purchase agreement. This product and its electronic accessories should not be mixed with other commercial waste.
	This marking indicates that the product and electronic accessories (eg. charger, USB cable, electronic material, controls, etc.) are susceptible to electric shock by direct or indirect contact with electricity. Be cautious when handling the product and observe all safety procedures in this manual.

01. SAFETY INSTRUCTIONS

STANDARDS TO FOLLOW

- It is important for your safety that these instructions are followed.
- Keep these instructions in a safe place for future reference.
- The **ELECTROCELOS S.A.** is not responsible for the improper use of the product, or other use than that for which it was designed.
- The **ELECTROCELOS S.A.** is not responsible if safety standards were not taken into account when installing the equipment, or for any deformation that may occur.
- The **ELECTROCELOS S.A.** is not responsible for insecurity and malfunction of the product when used with components that were not sold by the them.
- This product was designed and manufactured strictly for the use indicated in this manual.
- Any other use not expressly indicated may damage the product and/or can cause physical and property damages, and will void the warranty.
- Do not make any changes to the automation components and/or their accessories.
- Keep remote controls away from children, to prevent the automated system from being activated involuntarily.
- The customer shall not, under any circumstances, attempt to repair or tune the automatism. Must call qualified technician only.
- The installer must have certified professional knowledge at the level of mechanical assemblies in doors and gates and control board programming. He should also be able to perform electrical connections in compliance with all applicable regulations.
- The installer should inform the customer how to handle the product in an emergency and provide him the manual.
- This device can be used by children 8 year old or older and persons whose physical, sensory or mental capacities are reduced, or by persons without experience or knowledge if they have received supervision or instructions on the use of the device in a safe manner and understood the hazards involved. Children should not play with the device. Cleaning and maintenance by the user must not be carried out by unsupervised children.
- Before installing, the installer must verify that the temperature range indicated on the automatism is appropriate to the location of the installation.
- Before installing, the installer must verify that the equipment to be automated is in good mechanical condition, correctly balanced and opens and closes properly.
- If the automation is to be installed at a level higher than 2,5 m above ground

01. SAFETY INSTRUCTIONS

STANDARDS TO FOLLOW

- level or other level of access, , should be followed the minimum safety and health requirements for the use of work equipment workers at work in Directive 2009/104/EC of the European Parliament and of the Council of 16th September of 2009.
- In the case of the equipment where the automation will be installed, have a pedestrian door, be aware that it must be closed when the automation is activated.
 - After installation, make sure that the mechanism is properly adjusted and that the protection system and any manual unlocker works correctly.
 - In order to protect the electrical cables against mechanical stress, you should use conduit for the electrical wires, essentially on the power cable.
 - When programming the control unit, pay particular attention to touching only the location intended for that purpose. Failure to do so may result in electric shock.

02. OPERATOR

TECHNICAL SPECIFICATIONS

Technical specifications of the automated operator:

	800A		OL1500		OL2000	
	110V	230V	110V	230V	110V	230V
• Power supply	110V, 60Hz	230V, 50Hz	110V, 60Hz	230V, 50Hz	110V, 60Hz	230V, 50Hz
• Rated absorbed power	370W		550W		1000W	
• Max speed	12m/min		12m/min		12m/min	
• Noise	≤ 56dB		≤ 56dB		≤ 56dB	
• Operating temperature	>-25°C, <65°C		>-25°C, <65°C		>-25°C, <65°C	
• Protection class	IP44		IP44		IP44	
• Thermal protection (°C)	120°C		120°C		120°C	
• Leaf max weight (Kg)	800Kg		1500Kg		2000Kg	
• Working frequency	40%		70%		70%	
• Capacitor	35µF	12uF	60µF	16uF	25µF and 70µF	12,5uF and 25uF

DESCRIPTION



- Automated system for residential or industrial sliding gates with a maximum of 2000kgs. It consists of a reversing electro-mechanical gearmotor, powered by a 110 or 230V control unit.
- The automated system houses a programmable electronic control board that enables setting of function logics, work time and pause time, anti-crushing sensitivity as well as partial-opening width.
- The reversing system guarantees the gate will automatically lock when the motor is not operating.
- A release system enables the gate to be moved by hand in case of malfunction or emergency.
- The automated system was designed and built for controlling sliding gates. Do not use for any other purpose.

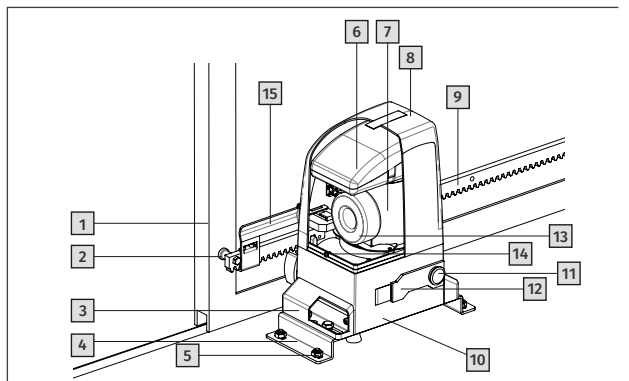

- 1 • Gate
- 2 • Rack spacer
- 3 • Protective cover
- 4 • Foundation plate
- 5 • Fixation screw
- 6 • Control box
- 7 • Motor
- 8 • Cover
- 9 • Rack
- 10 • Housing
- 11 • Lock
- 12 • Manual release
- 13 • Capacitor
- 14 • Screw
- 15 • Limit switch plate

02. OPERATOR

DIMENSIONS

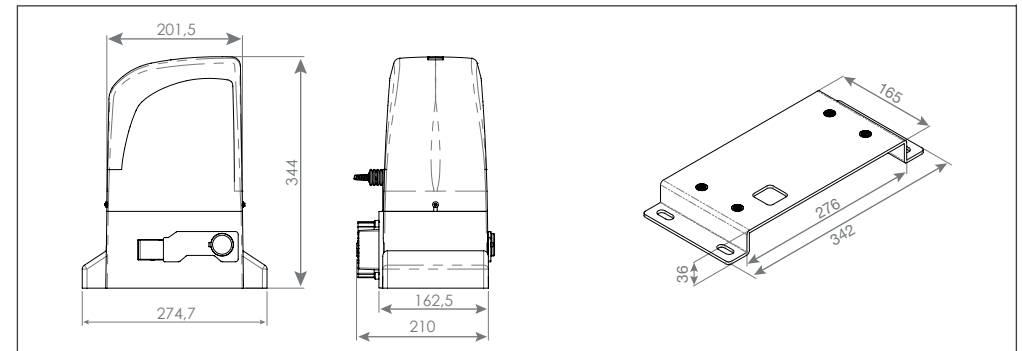

DESCRIPTION OF THE SYSTEM

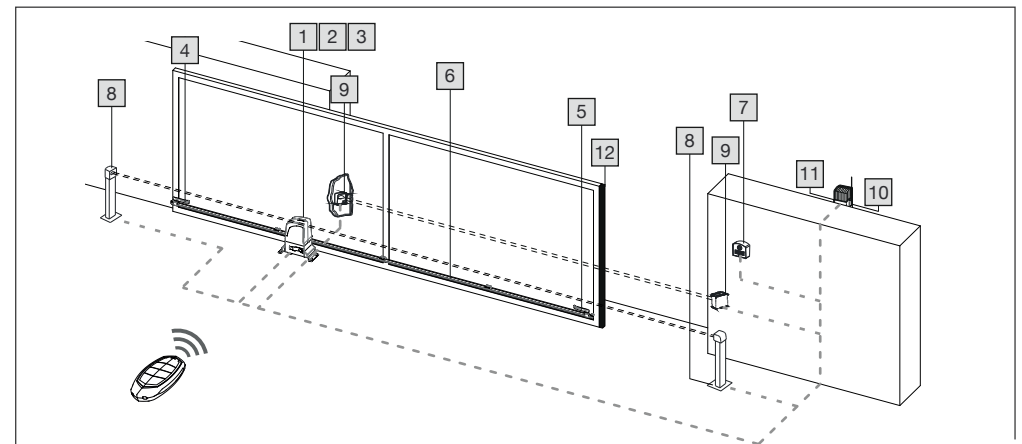

- 1 • Motor
- 2 • Control board
- 3 • Receiver
- 4 • Left limit switch plate
- 5 • Right limit switch plate
- 6 • Rack
- 7 • Key selector
- 8 • Photocell column
- 9 • Safety photocells
- 10 • Antenna
- 11 • Warning light
- 12 • Safety edge



- To lay down electric cables, use rigid and/or flexible adequate tubes.
- 2) To avoid any kind of interference, always separate low voltage connection cables from AC110 or 230V power cables.
 - 3) The description of system is standard system, but we did not provide all parts. If you want system accessories, please contact us.

02. OPERATOR

ACCESSORIES

You must check the operator packing before installing the automated system.

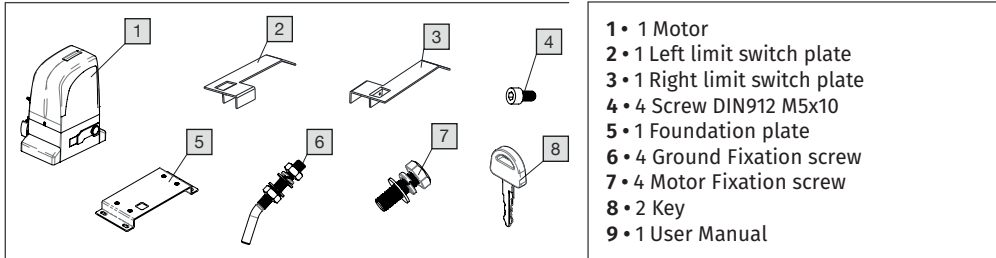

INSTALLATION TOOLS

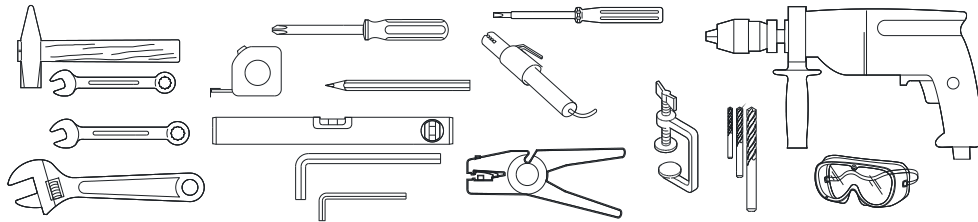

03. INSTALLATION

PRELIMINARY CHECKS



To ensure safety and an efficiently operating automated system, make sure the following conditions are applied:

- The structure of the gate must be suitable for being automated. In particular, check that the structure is sufficiently strong and rigid, and that its dimensions and weight conform to those indicated in the technical specifications;
- Make sure that the gate slides without any inclination;
- Make sure that the gate moves uniformly and correctly, without any irregular friction during its entire travel;
- The soil must permit sufficient stability for the expansion plugs securing the foundation plate;
- Remove any locks and lock bolts. We advise you to have any metalwork carried out before the automated system is installed.

03. INSTALLATION

PREPARING THE FOUNDATION PLATE

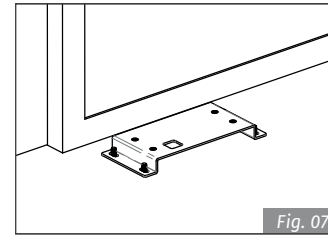
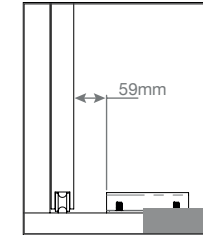

Fig. 07



Fit the 4 supplied nuts, as shown in Fig. 07 and Fig. 08, in the 4 holes of the plate.

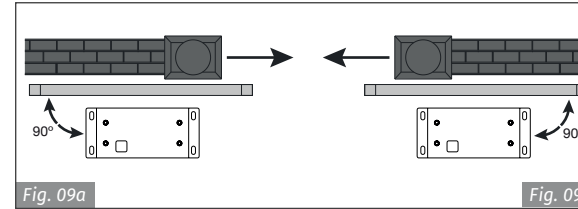

Fig. 09a

Fig. 09b

1 • The foundation plate must be located as shown in Fig. 9a (right closing) or Fig. 9b (left closing) to ensure the rack and pinion match correctly.

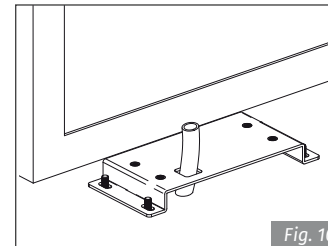

Fig. 10

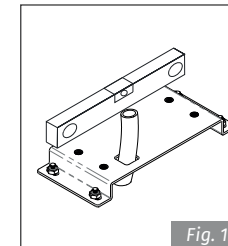

Fig. 11

2 • Put the foundation plate to the floor, using adequate expansion plugs and provide one or more tubes for routing the electric cables through the plate (Fig 10 and 11). Using a level, check if the plate is perfectly horizontal.

POSITIONING THE OPERATOR

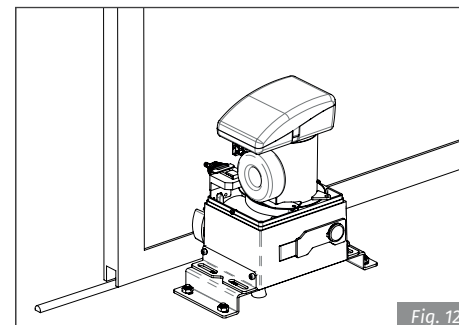
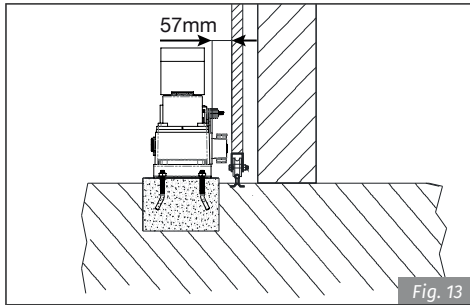

Fig. 12

Lay the electric cables to connect motor to accessories and power supply as shown in Fig. 4. To facilitate making the connections, allow the cables to project by the required length for connection to the control board, transformer and etc (if provided). Position the operator on the plate, using the supplied screws as shown in Fig. 12.

03. INSTALLATION

POSITIONING THE OPERATOR



Adjust the distance of the operator from the gate by referring to Fig.13.

FIXING OPERATOR

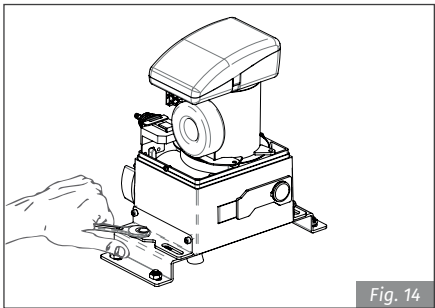
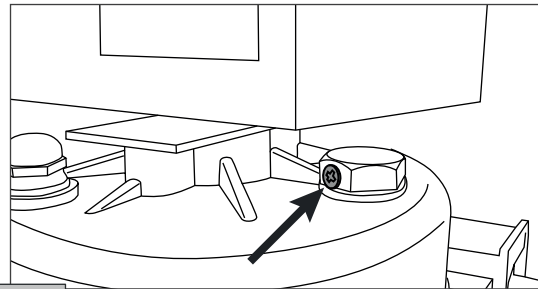

Fig. 14

1 • Fix the operator slightly tightening the screws as shown in Fig. 14.



After the installation, you must remove the exhaust screw (Applicable in OL1500 and 2000).

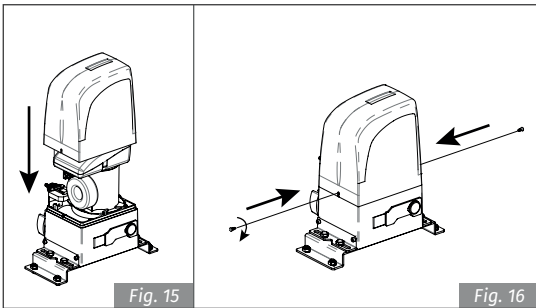

Fig. 15

Fig. 16

2 • After fixing the motor, screw cover (Fig. 15 and 16).

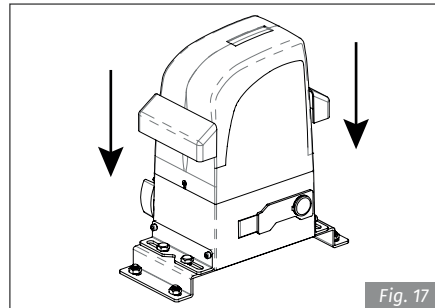

Fig. 17

3 • After the upper-cover fixed, please install the side-cover (Fig. 17).

03. INSTALLATION

RELEASING THE OPERATOR

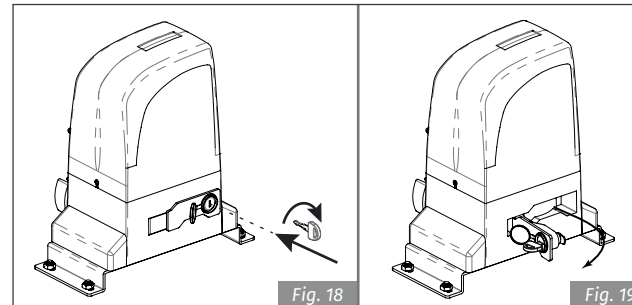

Fig. 18

Fig. 19

Insert supplied key on the lock, turn it clockwise 90° (Fig.18), pull and open the manual release (Fig.19).

After opened the manual release, you can operate the door manually.

INSTALLING THE RACK

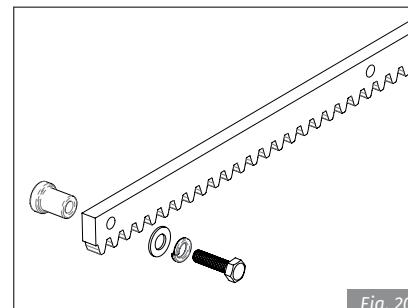

Fig. 20

1 • Prepare the rack to be applied. Putting these spacers in all holes of the rack in order to be completely secure.

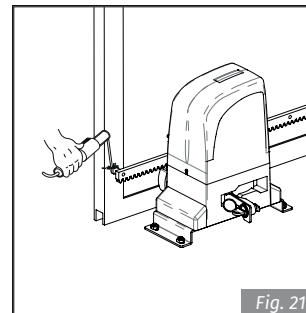

Fig. 21

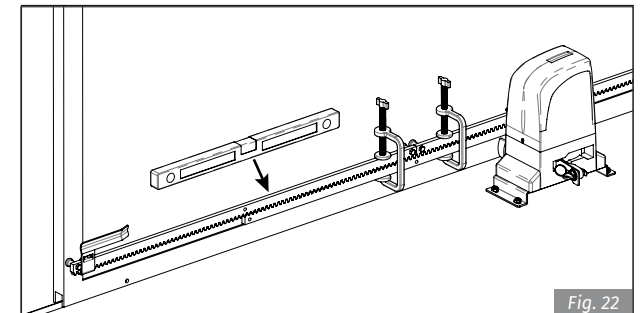

Fig. 22

2 • Manually put the gate leaf in the closed position.

3 • Positioning the first rack part to be bolted, supported on the pinion and with help of the level and clamping tool, keep it horizontally leveled.

4 • Move the gate to manually back and forth, to ensure that the gear rack is properly seated on the pinion and movement occurs smoothly.

5 • Set the rack in the gate. (Fig. 21). To ensure a correct fixation, can go slowly moving the gate and setting the gate spacers always near the pinion.

03. INSTALLATION

INSTALLING THE RACK

- 6 • Pull another element of the rack above, using a piece of additional rack teeth to synchronize the two elements (Fig. 22).
- 7 • Use a level again to make sure that rack is perfectly level.
- 8 • Manually move the gate and carry out the operations of attachment such as with the first element, proceeding up to the end of the gate.



- This motor can work with all types of racks.
- When installing nylon rack, make the application following the same steps described in the previous paragraphs. Start by placing the gate in the closed position, support the first meter of rack pinion on the engine and keeping it level horizontally, screw the first screw. Go opening the gate and tightening the remaining bolts. Continue adding more rack parts and repeating the same steps to complete the installation.
- Make sure that, during the gate travel, all the rack elements mesh correctly with the pinion.
- Do not, on any occasion, weld the rack elements either to the spacers. For fixing these, use screws and washers like in the Fig.20.
- Do not use grease or other lubricants between rack and pinion.

INSTALLING LIMIT SWITCH PLATE

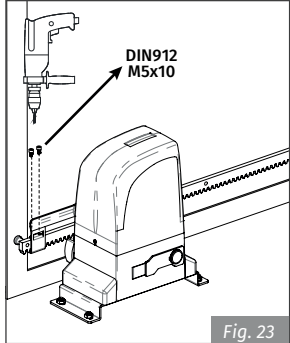

Fig. 23

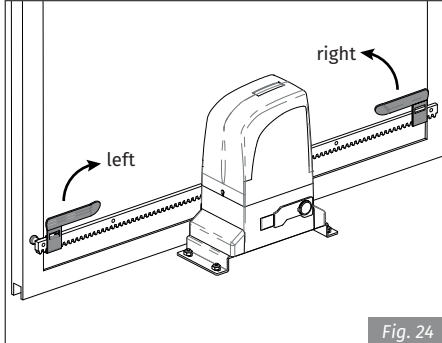

Fig. 24

- 1 • After having rack installed, take the gate back to the closed position and position the limit switch plate on the rack. In this closed position, the plate should trigger the limit switch of the motor.
- 2 • Tighten the screws DIN912 M5x12 included in the pack, until it touches the rack, squeezing it.

- 3 • Move the gate to the open position and repeat the same process for the other limit switch plate.
- 4 • The limit switch plates should be installed as in Fig. 24.

MAINTENANCE AND REPAIRS



- Carry out the following operations at least every 6 months:
- Check the efficiency of the release system.
 - Check the efficiency of the safety devices and accessories.
- For any repairs, pls contact the authorised repair centers.

03. INSTALLATION

CLUTCH ADJUSTMENT

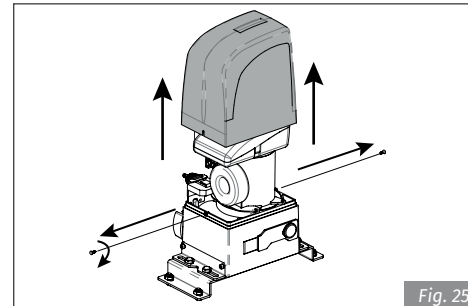

Fig. 25

- 1 • Unbolt the screws and remove the cover.

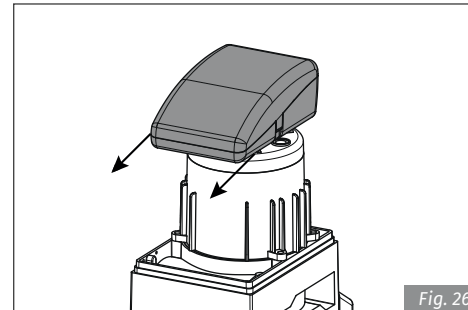

Fig. 26

- 2 • Access the adjusting screw. Slide the central box forward.

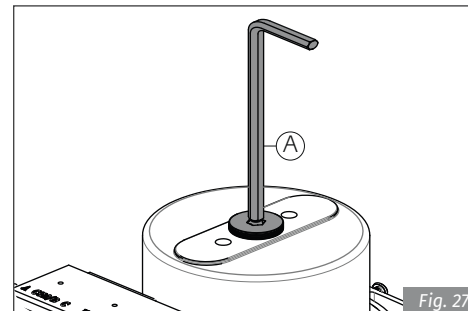

Fig. 27

- 3 • Adjust the screw in the upper part of the engine. To do this, it will require a 6mm umbrako key as shown in the image (A).

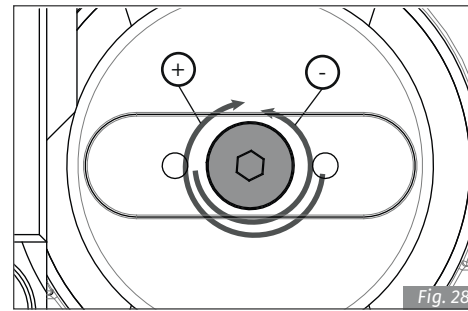

Fig. 28

- 4 • Do a test to the motor's irreversibility. To do that, just move the gate manually. If the gate is moving, it is necessary to refine the screw by turning clockwise (+).

If the gate does not move at idle, it means that the screw is tightened too much. Turn it counterclockwise (-) until the engine moves the gate at idle.

The tuning must achieve a balance between the gate's irreversibility and the engine's power.

04. CONNECTIONS OF THE MOTOR

FOR 800A/OL1500

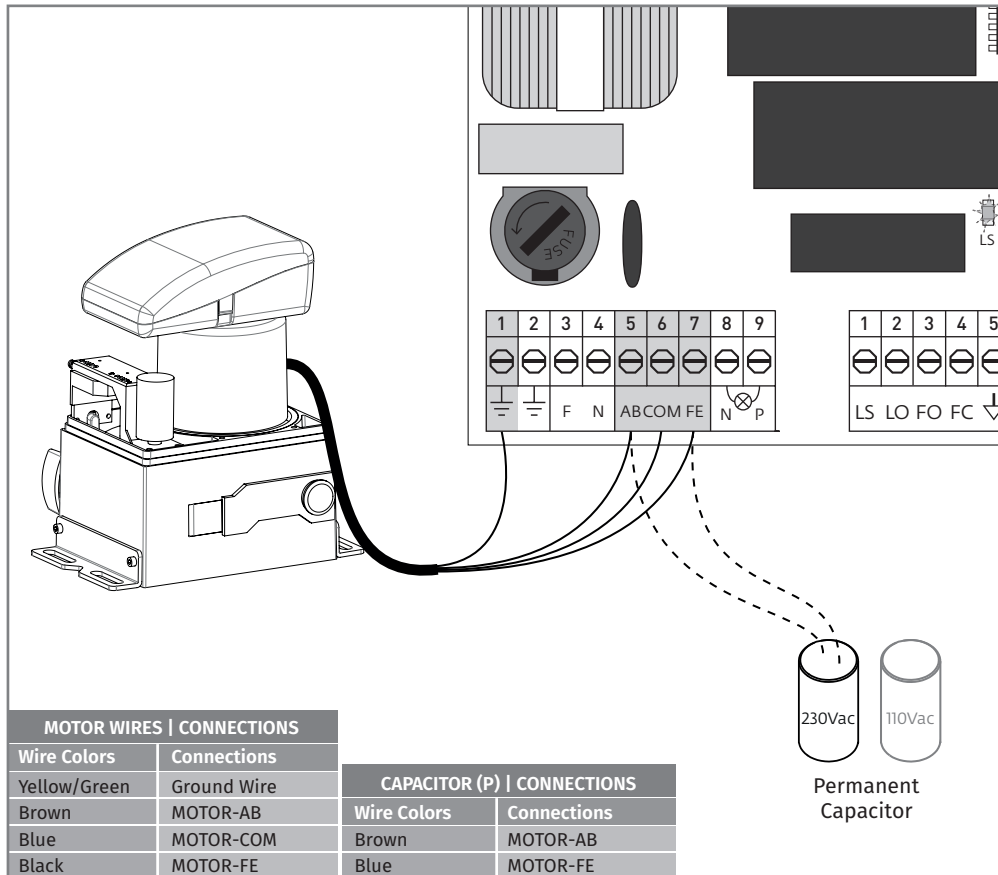

The motor connections must be made as shown above, by connecting the 4 motor wires to the appropriate inputs of the control board.

NOTE: The wires of the permanent capacitor (110Vac or 230Vac) must be connected directly to the control board as shown above.

04. CONNECTIONS OF THE MOTOR

FOR OL2000

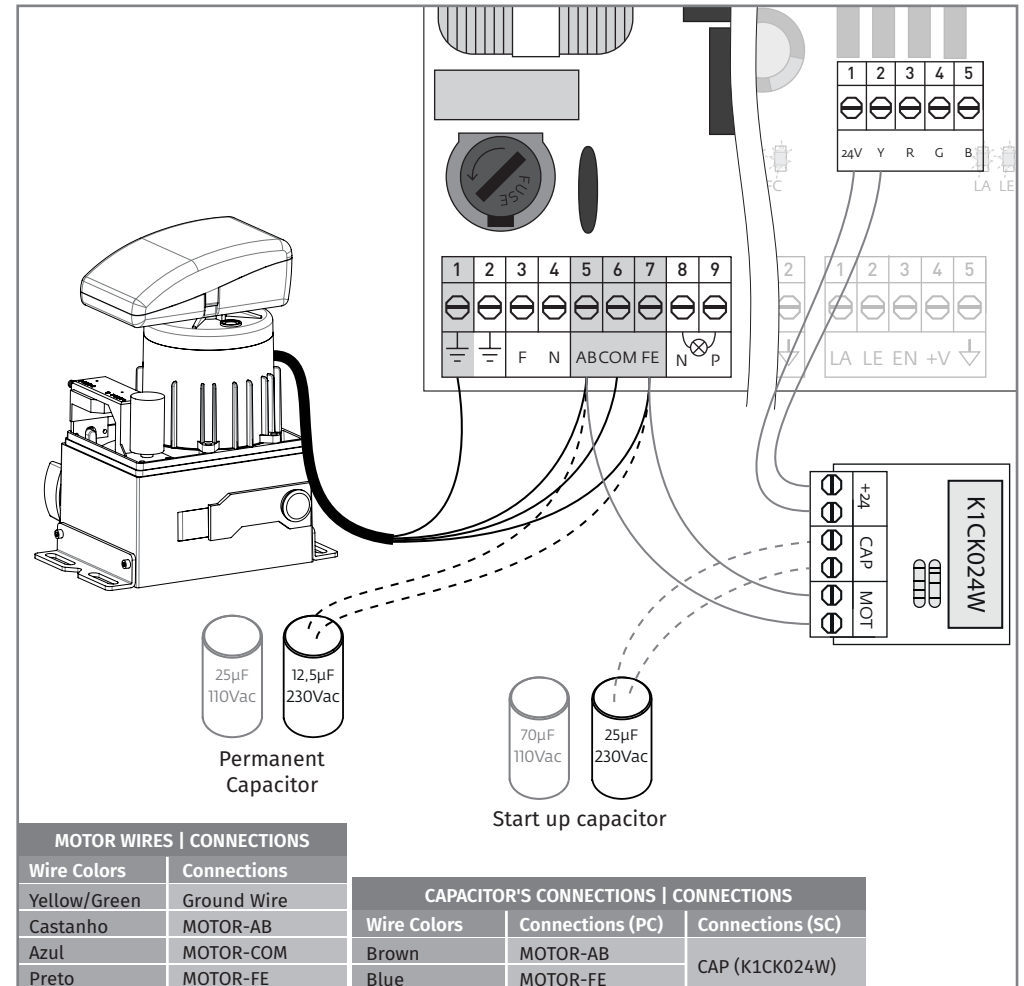

The motor connections must be made as shown above, by connecting the 4 motor wires to the appropriate inputs of the control board.

NOTE: In this motor you must use two capacitors, one of which works permanently and the other only works during the start up.

With 230Vac use 12.5µF + 25µF, and with 110Vac use 25µF + 70µF, connected as in the scheme above.