

A) Warning to the user and/or installer

- 1) CAUTION: It is important to your safety that these instructions are followed. The installation or misuse of this product may cause personal injuries or material damages.
- 2) Keep these instructions in a safe place for future reference.
- 3) This product was designed and produced strictly for the use indicated in this manual. Any other use other than the ones expressly indicated may damage the product and/or be a source of danger, invalidating the warranty.
- 4) STATEURUP is not liable for the incorrect use of this product, or another use other than the one for which it was designed.
- 5) STATEURUP is not liable if the safety standards were not taken into account when installing the equipment to be automated, or for any deformation that may occur to it.
- 6) Before the installation, turn off the power supply.
- 7) STATEURUP is not liable for the safety and proper installation of the product when are used components that are not sold by itself.
- 8) Do not make any changes to the motor components and/or accessories.
- 9) The installer should inform the customer how to operate the product in emergencies and provide him with a manual of use.
- 10) Keep the remote control out of reach of children, preventing the bollard to operate accidentally.
- 11) The customer shall not, in any circumstances, attempt to repair or tune the bollard. For this purpose, he must call a qualified technician.
- 12) Connect the bollard to a 230V power supply, with ground wire.
- 13) The equipment is determined for outdoor use.

CONFORMITY:

The firm STATEURUP declares, the automatic bollard MPIE10 follows the european norms and directives:

2006/95/CE-Low voltage electrical equipment;

89/336/CEE-Electromagnetic compatibility.

EN 60335-1, EN 55014-1, EN 55014-2, EN 61000-3-2, EN 61000-3-3

The firm STATEURUP declares, the control board MC11 follows the directive 95/05/EC (R&TTE)



B) Technical Specifications

1) Motor Specifications:

| | |
|---------------------------|-----------------|
| Model | WING400/600/800 |
| Input | 24 VDC |
| Power | 60 W |
| Intensity | 1.2 - 4A |
| Thermal Protection | 120°C |
| Temperature | >-20°C; <+50°C |

2) Control Box Specifications:

| | |
|--------------------------------|---------------------------|
| Model | MC11 |
| Input | AC230V, 50Hz |
| Fuse | 10 A |
| Output | 12 V DC / 250 mA / 24V DC |
| Temperature | >-10°C; <+55°C |
| Rising / Falling Time | 5 / 8 / 12 seg * |
| Automatic closing delay | 0 - 99 seg |

*with soft start/stop

3) Mechanical Specifications:

| | |
|------------------------|-------------------------------|
| Mobile piece | INOX 2.5 mm |
| Covers | Anti-Slip Stainless Steel 4mm |
| Fitted material | PVC 10 mm |

3) Physical Specifications:

| | |
|------------------------------------|--|
| Diameter | 204 mm |
| Course | 370 / 570 / 785 mm |
| Top flange | 400 mm |
| Fitted material | 320 x 320 x 870 / 320 x 320 x 1080 / 320 x 320 x 1280 (mm) |
| Weight capacity when closed | 20.000 Kg |
| Weight | 35 / 40 / 45 Kg |

C) Underground Bollard Installation

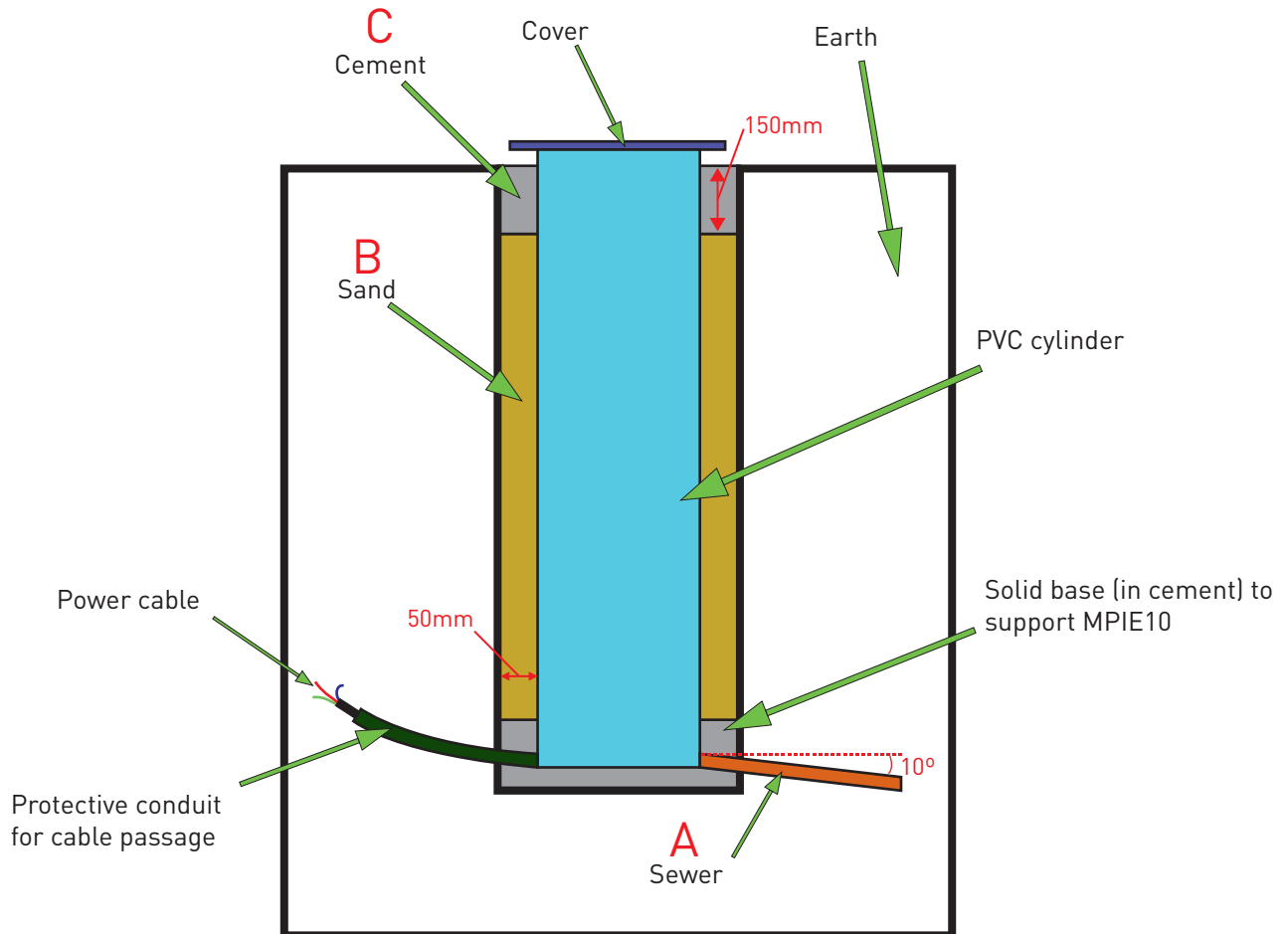

Figure 1: Bollard scheme

CAUTION:

1. **IMPORTANT!** Place the sewer with a minimum declination of 10°. **A**
2. Put sand around the bollard, for better accommodation. **B**
3. The cement must be made with sand. **C**
4. The control box must be installed in a place near the bollard, at a minimum height of 20cm from the ground.
5. If the distance from the control box to the bollard MP400/600/800 is bigger than 10 meters, use a 2.25mm power cable.

C) Underground Bollard Installation

In order to install the bollard, you can dismantle the cover, making the process much easier. To do that, you must remove the 6 screws furthest from the center, marked at red in Fig.2. Next, remove the cover as shown in Fig.3 and place the bollard in the hole (Fig. 5). Note that no waste or other objects fall into the inside of the bollard protecting the space using a piece of cloth, paper or other material serving as a seal between the stainless steel tube and the PVC pipe (Fig.6) . After placing the bollard in the hole and finishing the pavement around it, remove the material used for sealing and place the cover (Fig.3) in the bollard, fixing it with the six screws removed early in the process.

The bollard and it's cover must be aligned as shown in Fig.4.

The installation can be made without following these steps, however, it becomes more complex and harder, so, it's advised to follow the steps described above.

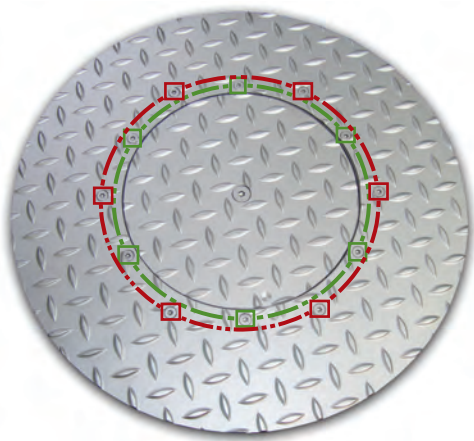

Figure 2: Cover



Figure 3: Removing Cover

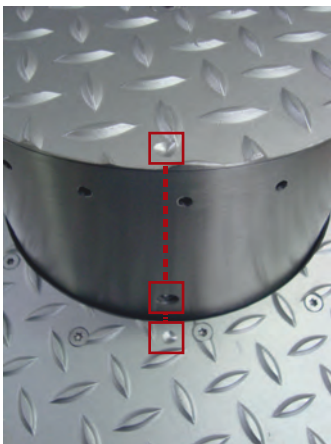

Figure 4: Bollard's alignment



Figure 5: Bollard installed



Figure 6: Seal the bollard

Important
Don't touch the screws marked at green - Fig.2

D) Dimensions

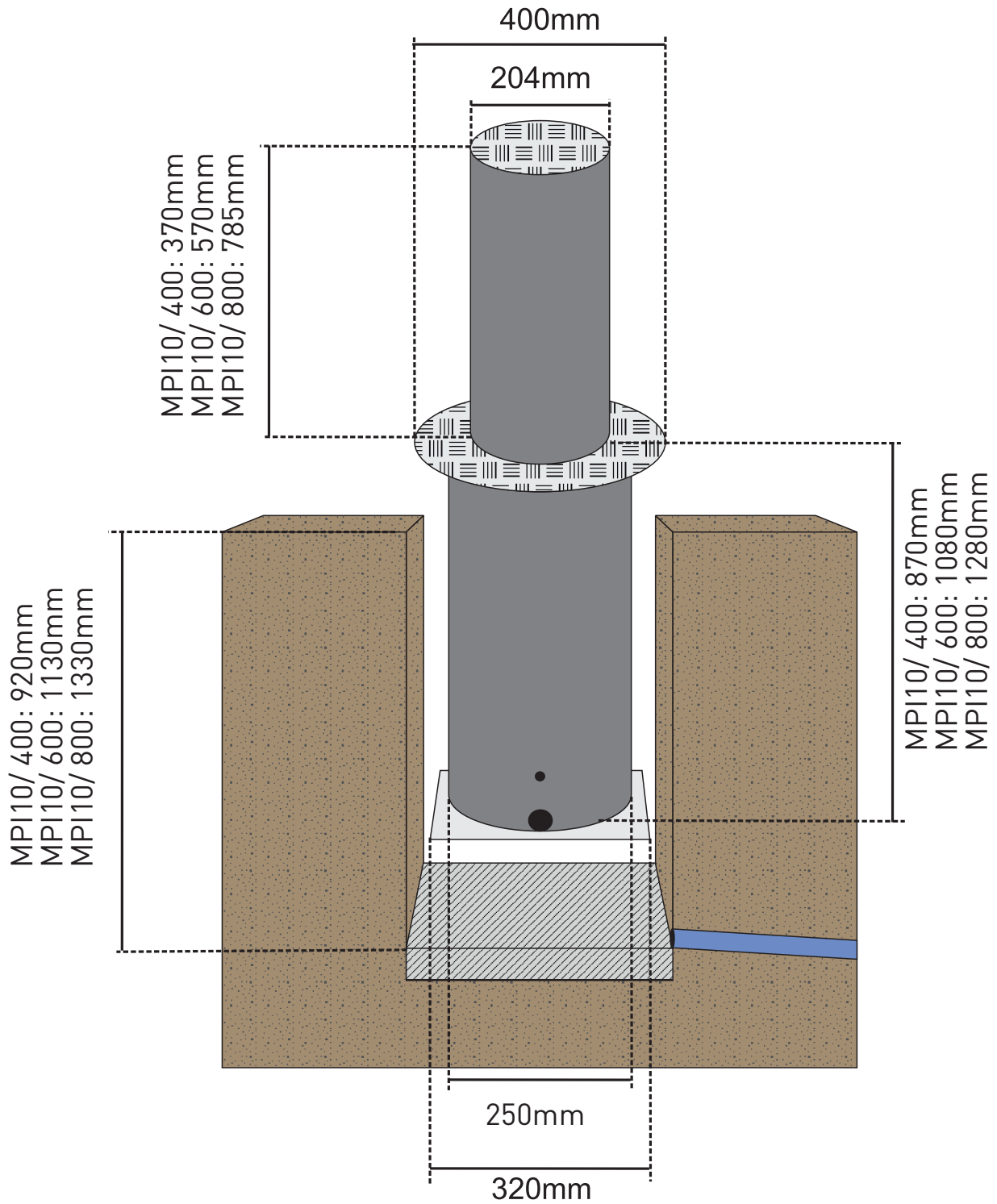

E) Electronic and Control

Control Box Specifications

- Input (transformer): 230 VAC
- Output (transformer): 24VAC
- Fuse: 10 A - 24V / 1 A - 220V
- Battery: 12V 1,2 Ah
- Codification: 433 MHz Rolling Code
- Receiver output: 12 VDC - 250 mA
- Temperature: -10°C / + 55 °C
- Protection: IP54
- Motor speed: 2800 RPM

Programming the Remote Controller:

The remote controller as already been programmed at the factory, but in case of a reset is done, it's necessary to program it again. To do so, follow the next steps:

Press the SEL button as many times as needed until the LED CODE starts blinking. After it, press the button desired in the remote controller and the LED CODE will remain alight confirming the reception of the code (proceed the same way for other controllers).

Programming the Bollard:

The bollard as already been programmed at the factory, but for several reasons unrelated to us it may be necessary to program it again. To program the opening and closing of the bollard be sure to proceed the following way:

- With the bollard opened (down) press the SEL button as many times as needed until the LED AUTO PGM starts blinking, and then press the SET button and wait for the bollard to do two complete manoeuvres (opening and closing), or in other words, until the LED AUTO PGM stops blinking.

Release the SET button.

The programming process is now complete.

(The battery only should be connected after all the installation process is completed)

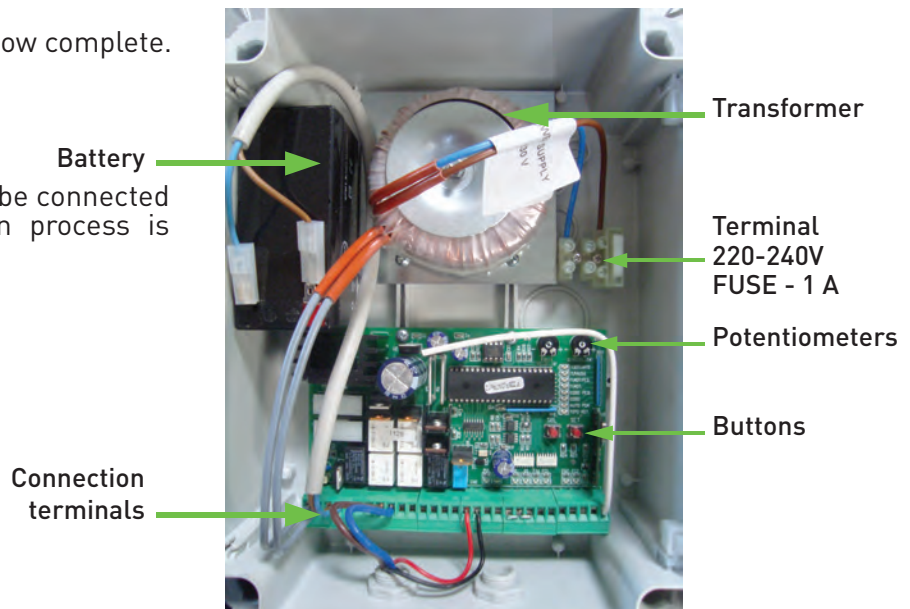

E) Electronic and Control

OBSERVATION:

The tuning of the power/velocity has already been programmed at the factory, so as the value of the sensibility. The bollard after each manoeuvre should turn itself off after 2 or 3 seconds, but in case this doesn't happen you'll have to adjust the sensibility potentiometer in the + direction (right).

In case that the manoeuvre isn't completed you'll have to adjust the same potentiometer a bit to the left side.

In the end you should repeat the bollard programming process.

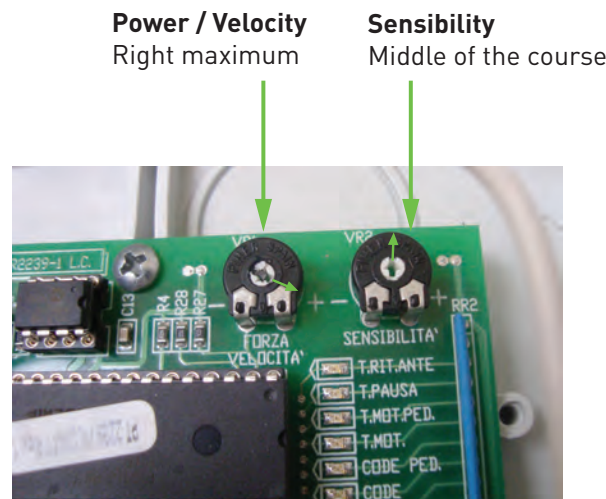

Reset of the Control Board (memory cleaning)

In order to perform a general cleaning to the control board's memory and start a new programming process, you should press the SEL and SET buttons at the same time until all the LEDs of the board light up.

The reset is complete and you may now program the control board.

- To get additional information about the control box and other functions (ex: Photocells), you should consult your reseller.

E) Unlocking

Unlocking the bollard in case of an emergency, power outage or malfunction.



Slot to make the release



Rotate the key in clockwise direction

IMPORTANT

- After unlocking, the MPIE10 400/600/800 will descend automatically.
- In case of power outage, the bollard is prevented by a battery that has enough power to make one manoeuvre (open or close). You shall not use the bollard anymore until there is a power supply at 230V because the battery was designed for emergencies only. In case you use the bollard more than 1 time powered only by the battery, it may not have enough energy and an incomplete manoeuvre may occur.
- In case of malfunction of the equipment, you shall call a qualified technician.

IMPORTANT

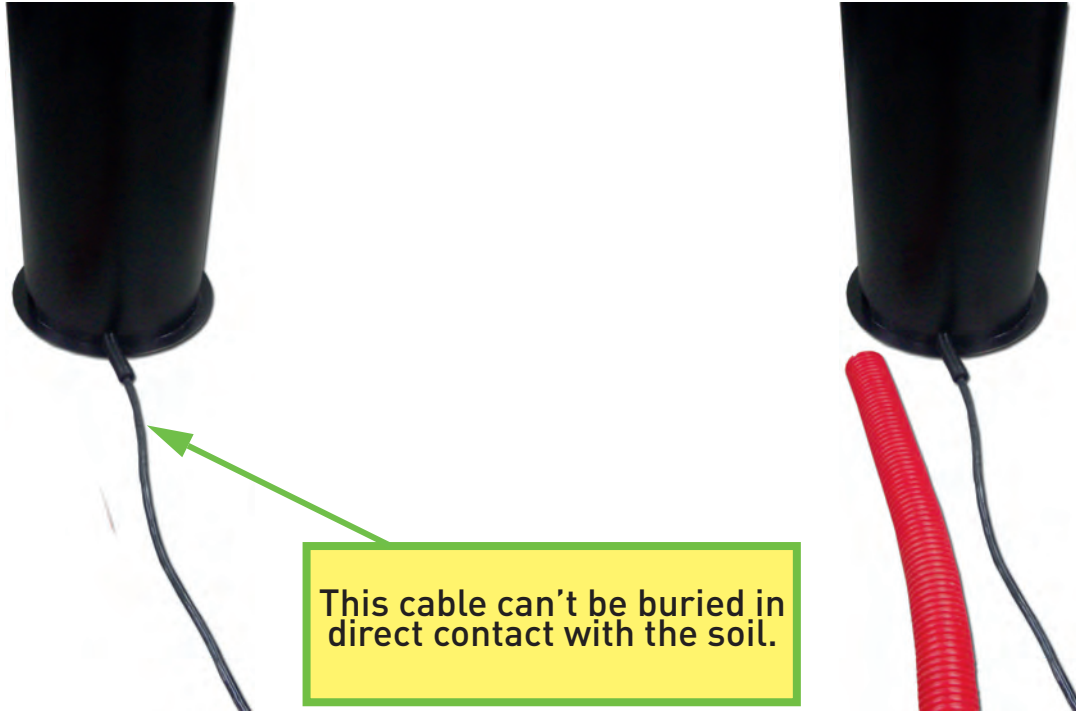

ATTENTION!

A protective conduit must be used
for underground cable passage.

- (PT) Esquema de Ligação - MC11 (RGB Led's + MSC50)
- (DE) Verbindungsschema - MC11 (RGB Led's + MSC50)
- (ES) Esquema de enlace - MC11 (RGB Led's + MSC50)
- (EN) Link Scheme - MC11 (RGB Led's + MSC50)
- (FR) Schéme de connexion - MC11 (RGB Led's + MSC50)
- (IT) Schema di collegamento - MC11 (RGB Led's + MSC50)

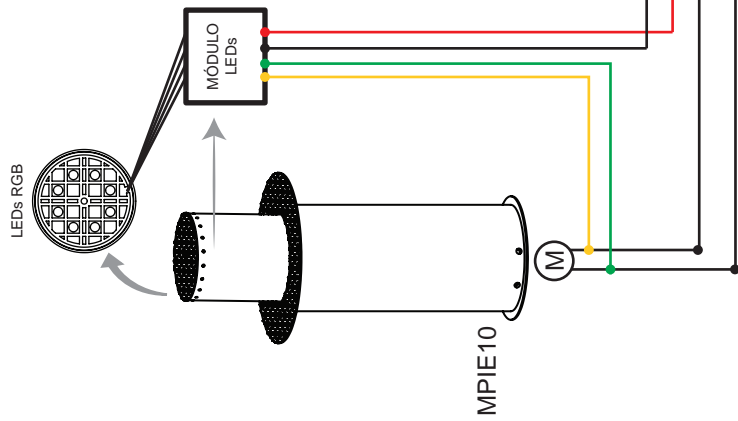

(PT) Transformador / (DE) Transformator
 (ES) Transformador / (EN) Transformer
 (FR) Transformateur / (IT) Trasformatore
230V/12VAC 50/60Hz 120w MAX
230V/24VAC 50/60Hz 120w MAX

Aviso / Hinweis / Aviso / Notice / Avis / Avviso

- (PT) Quando motor roda no sentido contrário, troque o fio preto com o castanho
- (DE) Motorlaufrichtung ändern durch Tauschen des schwarzen mit dem braunen Kabel
- (ES) El motor gira en la dirección equivocada - Cambie los cables negro con marrón
- (EN) Motor turning in wrong direction - Swap the black wires with brown wire
- (FR) Le moteur tourne dans le mauvais sens - Remplacer les fils marron avec fils noir
- (IT) Motore ruota nella direzione sbagliata - Cambiare i fili nero con marrone

