



MC112N | MC113N | MC114N

USER'S AND INSTALLER'S MANUAL







00.CONTENT

INDEX

01. SAFETY INSTRUCTIONS	1B
02. PRODUCT	
DESCRIPTION OF PRODUCT	4A
TECHNICAL CHARACTERISTICS	4A
DIMENSIONS	4A
COMPONENTS MAP	4B
03. COMPONENTS	
MR13- RECEIVER	5A
MX13 - TRANSMITTER	5B
04. VARIATORS AND CONECTORS	
FREQUENCY VARIATORS	6
FREQUENCY VARIATORS CONNECTIONS	7A
CONNECTIONS CONNECTORS	7B
05. CONNECTIONS SQUEME	
FREQUENCY VARIATOR CONNECTIONS	8
MR13 RECEIVER CONNECTIONS	9
OTHER CONNECTIONS (MAGNETIC SPACER, BRAKING RESITOR AND ENTRY PANEL)	10
CLOSING PRE- FLASHING LIGHT	11
RELAY FOR TWO-DOOR INTERLOCK	12
EXTERNAL COMPONENTS CONNECTIONS	13
06. DESCRIPTIONS	
DIGITAL NUMERIC KEYBOARD	14A
MENU NAVIGATION	14B
LOCK/UNLOCK KEYBOARD	15A
PROGRAMMING MENU ACCESS (MENU 04)	15B
PROGRAMMING MENU - 04	16A
07. PROGRAMMING	
ADJUSTMENT OF LIMIT SWITCHES	17
LED DISPLAY MESSAGES	18A
08. TROUBLESHOOTING	
INSTRUCTIONS FOR CONSUMERS AND SPECIALIZED TECHNICIANS	18B

01. SAFETY INSTRUCTIONS

ATTENTION:

	This product is certified in accordance with European Community (EC) safety standards.
	This product complies with Directive 2011/65/EU of the European Parliament and of the Council, of 8 June 2011, on the restriction of the use of certain hazardous substances in electrical and electronic equipment.
	(Applicable in countries with recycling systems). This marking on the product or literature indicates that the product and electronic accessories (eg. Charger, USB cable, electronic material, controls, etc.) should not be disposed of as other household waste at the end of its useful life. To avoid possible harm to the environment or human health resulting from the uncontrolled disposal of waste, separate these items from other types of waste and recycle them responsibly to promote the sustainable reuse of material resources. Home users should contact the dealer where they purchased this product or the National Environment Agency for details on where and how they can take these items for environmentally safe recycling. Business users should contact their vendor and check the terms and conditions of the purchase agreement. This product and its electronic accessories should not be mixed with other commercial waste.
	
	This marking indicates that the product and electronic accessories (eg. charger, USB cable, electronic material, controls, etc.) are susceptible to electric shock by direct or indirect contact with electricity. Be cautious when handling the product and observe all safety procedures in this manual.

01. SAFETY INSTRUCTIONS

GENERAL WARNINGS

- This manual contains very important safety and usage information, very important. Read all instructions carefully before beginning the installation/usage procedures and keep this manual in a safe place that it can be consulted whenever necessary.
- This product is intended for use only as described in this manual. Any other enforcement or operation that is not mentioned is expressly prohibited, as it may damage the product and put people at risk causing serious injuries.
- This manual is intended firstly for specialized technicians, and does not invalidate the user's responsibility to read the "User Norms" section in order to ensure the correct functioning of the product.
- The installation and repair of this product may be done by qualified and specialized technicians, to assure every procedure are carried out in accordance with applicable rules and norms. Nonprofessional and inexperienced users are expressly prohibited of taking any action, unless explicitly requested by specialized technicians to do so.
- Installations must be frequently inspected for unbalance and the wear signals of the cables, springs, hinges, wheels, supports and other mechanical assembly parts.
- Do not use the product if it is necessary repair or adjustment is required.
- When performing maintenance, cleaning and replacement of parts, the product must be disconnected from power supply. Also including any operation that requires opening the product cover.
- The use, cleaning and maintenance of this product may be carried out by any persons aged eight years old and over and persons whose physical, sensorial or mental capacities are lower, or by persons without any knowledge of the product, provided that these are supervision and instructions given by persons with experienced in terms of usage of the product in a safe manner and who understands the risks and dangers involved.
- Children shouldn't play with the product or opening devices to avoid

the motorized door or gate from being triggered involuntarily.

WARNINGS FOR TECHNICIANS

- Before beginning the installation procedures, make sure that you have all the devices and materials necessary to complete the installation of the product.
- You should note your Protection Index (IP) and operating temperature to ensure that is suitable for the installation site.
- Provide the manual of the product to the user and let them know how to handle it in an emergency.
- If the automatism is installed on a gate with a pedestrian door, a door locking mechanism must be installed while the gate is in motion.
- Do not install the product "upside down" or supported by elements do not support its weight. If necessary, add brackets at strategic points to ensure the safety of the automatism.
- Do not install the product in explosive site.
- Safety devices must protect the possible crushing, cutting, transport and danger areas of the motorized door or gate.
- Verify that the elements to be automated (gates, door, windows, blinds, etc.) are in perfect function, aligned and level. Also verify if the necessary mechanical stops are in the appropriate places.
- The central must be installed on a safe place of any fluid (rain, moisture, etc.), dust and pests.
- You must route the various electrical cables through protective tubes, to protect them against mechanical exertions, essentially on the power supply cable. Please note that all the cables must enter the central from the bottom.
- If the automatism is to be installed at a height of more than 2,5m from the ground or other level of access, the minimum safety and health requirements for the use of work equipment workers at the work of Directive 2009/104/CE of European Parliament and of the Council of 16 September 2009.
- Attach the permanent label for the manual release as close as possible

01. SAFETY INSTRUCTIONS

to the release mechanism.

- Disconnect means, such as a switch or circuit breaker on the electrical panel, must be provided on the product's fixed power supply leads in accordance with the installation rules.
- If the product to be installed requires power supply of 230Vac or 110Vac, ensure that connection is to an electrical panel with ground connection.
- The product is only powered by low voltage safety with central (only at 24V motors)

WARNINGS FOR USERS

- Keep this manual in a safe place to be consulted whenever necessary.
- If the product has contact with fluids without being prepared, it must immediately disconnect from the power supply to avoid short circuits, and consult a specialized technician.
- Ensure that technician has provided you the product manual and informed you how to handle the product in an emergency.
- If the system requires any repair or modification, unlock the automatism, turn off the power and do not use it until all safety conditions have been met.
- In the event of tripping of circuits breakers or fuse failure, locate the malfunction and solve it before resetting the circuit breaker or replacing the fuse. If the malfunction is not repairable by consult this manual, contact a technician.
- Keep the operation area of the motorized gate free while the gate in in motion, and do not create strength to the gate movement.
- Do not perform any operation on mechanical elements or hinges if the product is in motion.

RESPONSABILITY

- Supplier disclaims any liability if:
 - Product failure or deformation result from improper installation use or maintenance!
 - Safety norms are not followed in the installation, use and maintenance of the product.
 - Instructions in this manual are not followed.
 - Damaged is caused by unauthorized modifications
 - In these cases, the warranty is voided.

SYMBOLS LEGEND:



• Important safety notices



• Useful information



• Programming information



• Potentiometer information



• Connectors information



• Buttons information

02. PRODUCT

DESCRIPTION OF PRODUCT

- Control board capable of working with motors up to 750W, 1500W and 2200W. It has a frequency variator that allows a soft start and stop, thus giving a greater reliability and durability of the product. The central also allows the adjustment of the opening / closing speed as well as the adjustment of the opening / closing deceleration speed.
- This central allows easy and intuitive operation of various parameters and menus through a display.
- It also has other functions such as Present Man, possibility to view the count of cycles perform by the door so far (complete opening and closing corresponds to one cycle).
- This central is also capable of receiving command signals ROLLING CODE (receiver MR13) and allows connection for obstacle detection kits (MX13 transmitter).

TECHNICAL CHARACTERISTICS

	MC112N	MC114N	MC113N
• Voltage	750W max	1500W max	2200W max
• Power Supply	230Vac 50/60Hz		
• Protection Grade	IP64		
• Environment temperature	-25°C ~ 55°C		
• Relative Humidity	<90%		
• Accessory output	24Vdc 3W / 12Vdc 2W		
• Maximum frequency output	90Hz		

DIMENSIONS

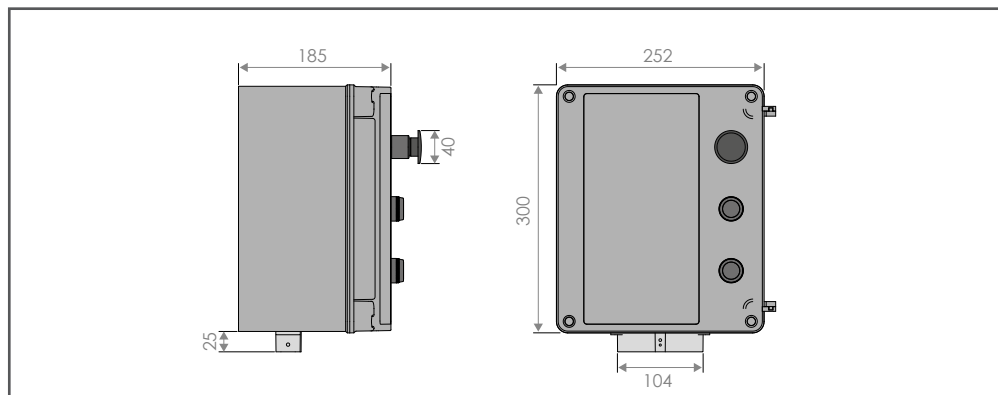

02. PRODUCT

COMPONENTS MAP

The control board is composed of the following components:

- 1 • Frequency variator
- 2 • Connections connectors
- 3 • MR13 Receptor
- 4 • Braking Resistance
- 5 • Magnetic Spacer (Optional)
- 6 • Quick connection sheet
- 7 • STOP key
- 8 • Opening key
- 9 • Close key
- 10 • Mirror Photocell
- 11 • MX13 Transmitter (see page 5B)

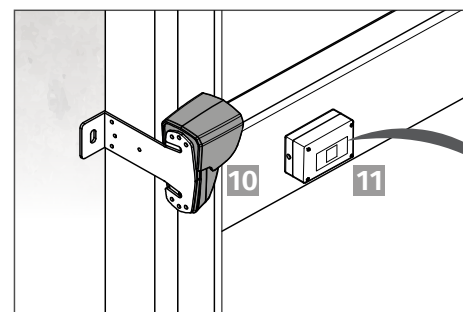
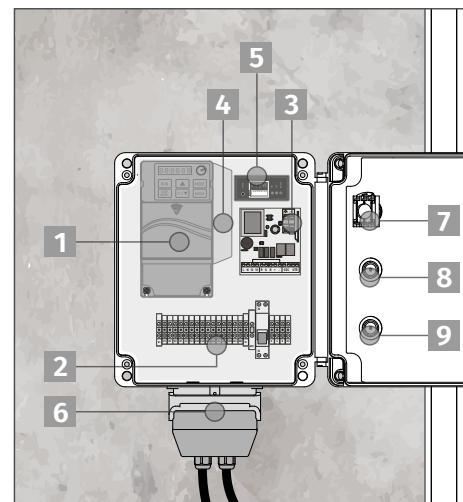

IMPORTANT

Before starting programming, it is necessary to remove the card from the receiver's batteries, otherwise the door will not perform any type of maneuver.

03. COMPONENTS

MR13- RECEIVER

Wireless receiver, which allows the reception of Motorline ROLLING CODE remote controllers and MX13 transmitters signals, for safety circuits (eg safety bands, magnetic contacts). This receiver allows the use of a single MX13 transmitter.



DIPPER

• **Dippers 1 and 2** define the time interval for receiving test signals MX13. This communication is made to ensure that both handsets are working perfectly.

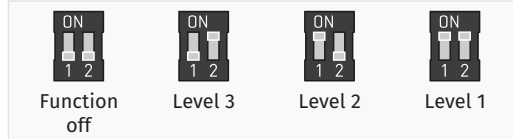

• For the MX13 and MR13 devices to be synchronized, you must configure **dippers 1 and 2** in the same way on both devices.



LEARN BUTTON

• This button is used when programming Rolling Code Motorline remote controllers or MX13 transmitter.

Programming Remote Control:

- 1 • Press the **LEARN** button once and the **LED4** will blink once.
- 2 • Then press the button you want to program.

Programming MX13 transmitter:

- 1 • Press rapidly the **LEARN** button 2 times and the **LED4** flashes 2 times.
- 2 • Press the **PROG** button on the MX13 only once.

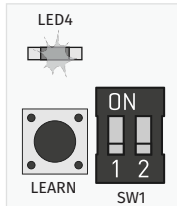

- To reset the memory, press the button for 10 seconds and all memorized remote controls and MX13 will be erased.
- While pressing the **LEARN** button, the **LED4** is on. After 10 seconds, the **LED4** will flash and switch off confirming the operation.



LEDs

- **LED 1:** (ON) Indicates that it is being powered at 230V ac.
- **LED 2:** (ON) Contact "SEC" closed | Contact "SEC" opened (every time an MX13 signal is sent the contact opens).
- **LED 3:** (ON) Contact "STR" closed | Contact "STR" opened
- **LED 4:** Programming Led

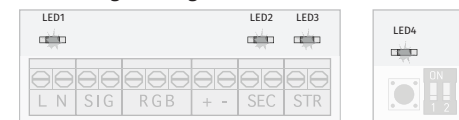

CONNECTORS

- **L/N:** 230Vac power input.
- **SIG:** Pulse input
- **R/G/B:** RGB led connection
- **+/-:** Power supply of external accessories (max 150mA).
- **SEC:** NC safety signal output.
- **STR:** NO Opening signal output
- **ANT:** Antenna hot pole input
- **↓:** Antenna mass input



03. COMPONENTS

MX13 - TRANSMITTER

Wireless transmitter, which allows the connection of obstacle detection kits (safety rubber, magnetic contact, etc.), for communication with MR13. This device performs automatic operation tests with MR13, at defined time intervals, providing a longer battery life.



Not include in **ECO** and **ECO PLUS** doors.



DIPPER

• **Dippers 1 and 2** define the time interval for receiving test signals MX13. This communication is made to ensure that both handsets are working perfectly.

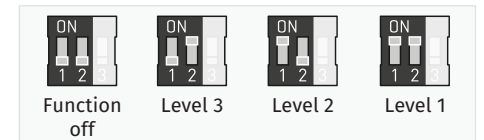

- The more frequent communication with the MR13 receiver, the shorter the battery life.
- For MX13 and MR13 devices to be synchronized, you must configure dippers 1 and 2 in the same way on both devices.

• Dipper 3 defines the type of operation of the SAFETY input, between 8K2 system and NO contact.

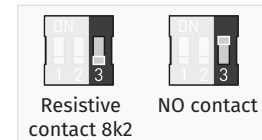

PROG AND LED 1 BUTTON

- The PROG button has the function of generating a new code, and transmitting it to the receiver. Each time the button is pressed, LED1 illuminates, indicating that the signal is being transmitted.



Each time the PROG button is pressed, the transmitted code is changed. Therefore, if you press the PROG button, you have to program it again on the MR13 (see page 5A).

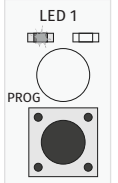

CONNECTOR



- **INIB** - This input has the function to disable the operation of the SAFETY input, through a NO contact for connection of push button or magnetic contact.



- **SAFETY** - NO or 8K2 input, defined in dipper 3. Whenever this input is triggered an order will be sent to the MR13 to open the SEC contact.

Example of use:

When the MX13 device is installed on a sectioned door with safety rubber, it is necessary to disable the SAFETY signal before the gate closes fully, so that the rubber does not send reverse order due to obstacle detection.

04. VARIATORS AND CONECTORS

FREQUENCY VARIATORS

MC112N (Up to 750W)

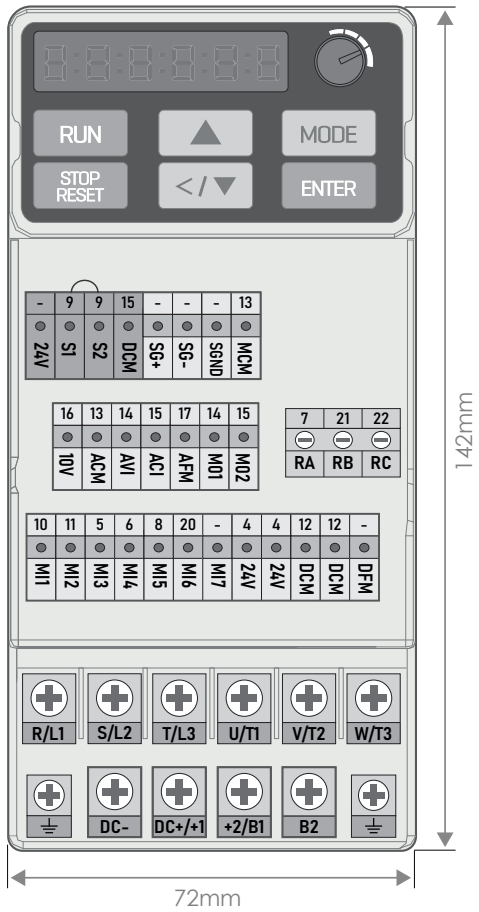

MC114N (Up to 1500W)

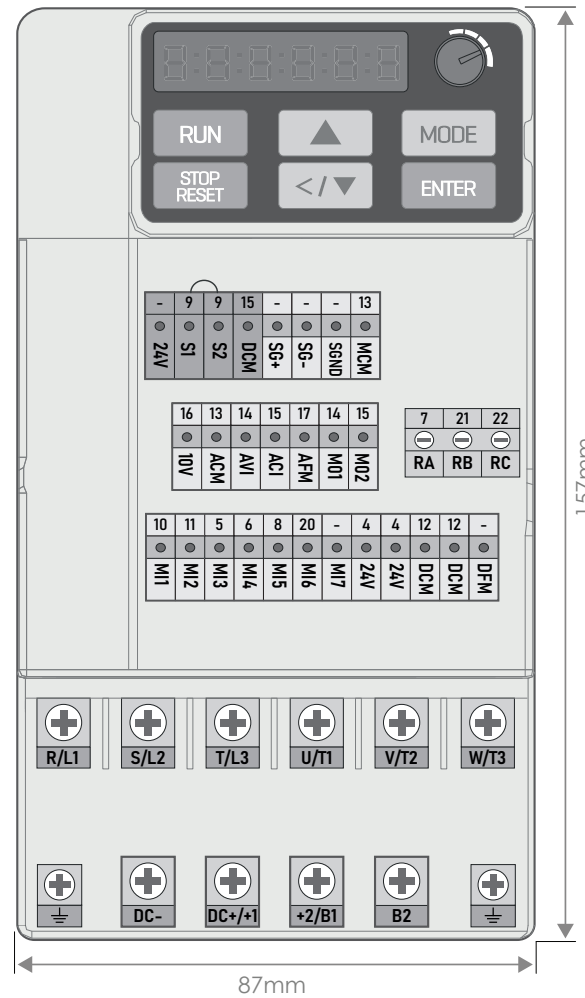

MC113N (Up to 2200W)

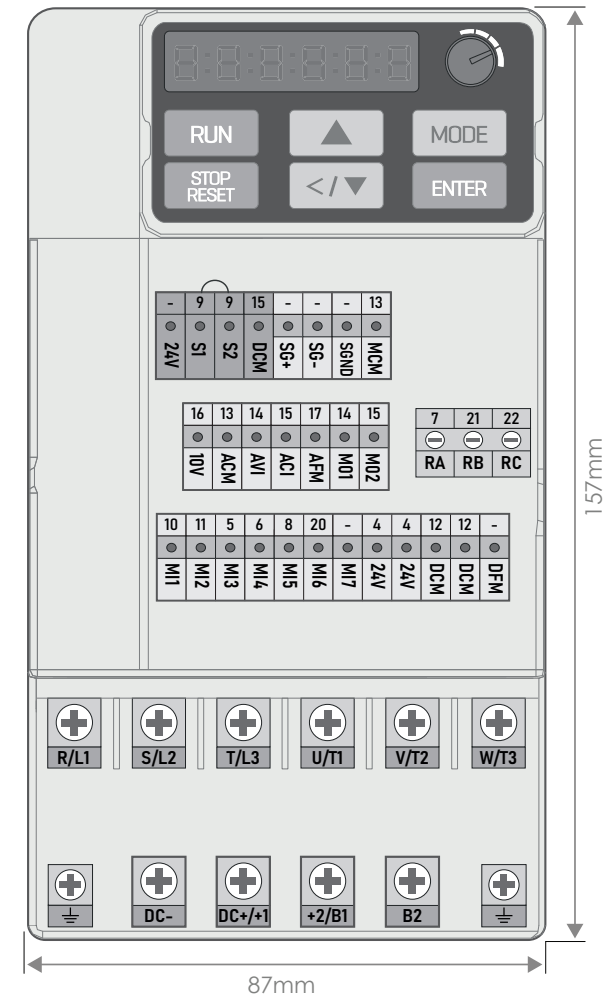

The frequency inverters have different dimensions depending on their power. The MC114N inverter is used as a reference for the connections scheme in this manual, however their connections are the same.

04. VARIATORS AND CONECTORS

FREQUENCY VARIATORS CONNECTIONS

The following panel are all inputs and outputs of frequency variator.

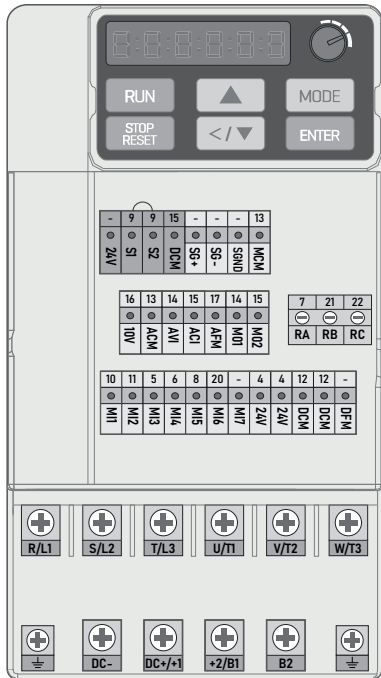

R/L1 • 230Vac Power Supply
S/L2 • 230Vac Power Supply

U/T1 • Motor output – Phase 1
V/T2 • Motor output – Phase 2
W/T3 • Motor output – Phase 3
T/L3 • Not used

⊥ • Ground
DC- • Not used
DC+ / +1 • Not used
+2/B1 • Braking resistance connection
B2 • Braking resistance connection
 ⊥ • Ground

- 24V** • Common STOP
- S1** • STOP key
- S2** • STOP key
- DCM** • Not used
- SG+** • Not used
- SG-** • Not used
- SGND** • Not used
- MCM** • Voltage input for **M01** and **M02** outputs
- 10V** • Not used
- ACM** • Not used
- AVI** • Not used
- ACI** • Not used
- AFM** • Not used
- M01** • Pulse output for MR13
- M02** • Optional misfeed relay output or pre- flashing light. Programmable at **parameter 04.61**
- MI1** • Opening key
- MI2** • Closing key
- MI3** • Limit switch
- MI4** • Limit switch
- MI5** • Photocells
- MI6** • STOP button
- MI7** • Not used
- 24V** • Photocells and Radars Input (24Vdc 3W)
- 24V** • Photocells and Radars Input (24Vdc 3W)
- DCM** • Negative output 24Vdc 3W
- DCM** • Negative output 24Vdc 3W
- DFM** • Not used
- RA** • NO relay output for electric brake
- RB** • Not used
- RC** • Common relay for electric brake

04. VARIATORS AND CONECTORS

CONNECTIONS CONNECTORS

The below panel are all inputs and outputs of connection connectors.

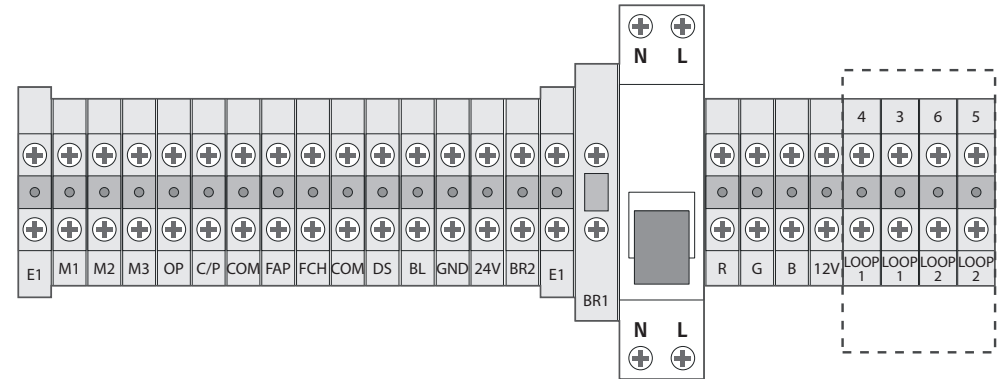

- E1** • Ground
- M1** • Motor output – Phase 1
- M2** • Motor output – Phase 2
- M3** • Motor output – Phase 3
- OP** • Opening key
- C/P** • Lock/Pedestrian Button
- COM** • Common
- FAP** • Opening limit switch
- FCH** • Closing limit switch
- COM** • Common
- DS** • Photocells input
- BL** • STOP
- GND** • 24V Negative
- 24V** • Photocells and Radars Input (24Vdc 3W)
- BR1** • Output with electric brake fuse (1A 250V fuse)
- BR2** • Electric brake

- E1** • Ground
- N** • 230Vac Power Supply
- L** • 230Vac Power Supply
- R** • RED LED output
- G** • GREEN LED output
- B** • BLUE LED output
- 12V** • 12Vdc 2W LED Power Supply
- LOOP1** • LOOP1 for Magnetic Spacer
- LOOP1** • LOOP1 for Magnetic Spacer
- LOOP2** • LOOP2 for Magnetic Spacer
- LOOP2** • LOOP2 for Magnetic Spacer

05. CONNECTIONS SQUEME

FREQUENCY VARIATOR CONNECTIONS

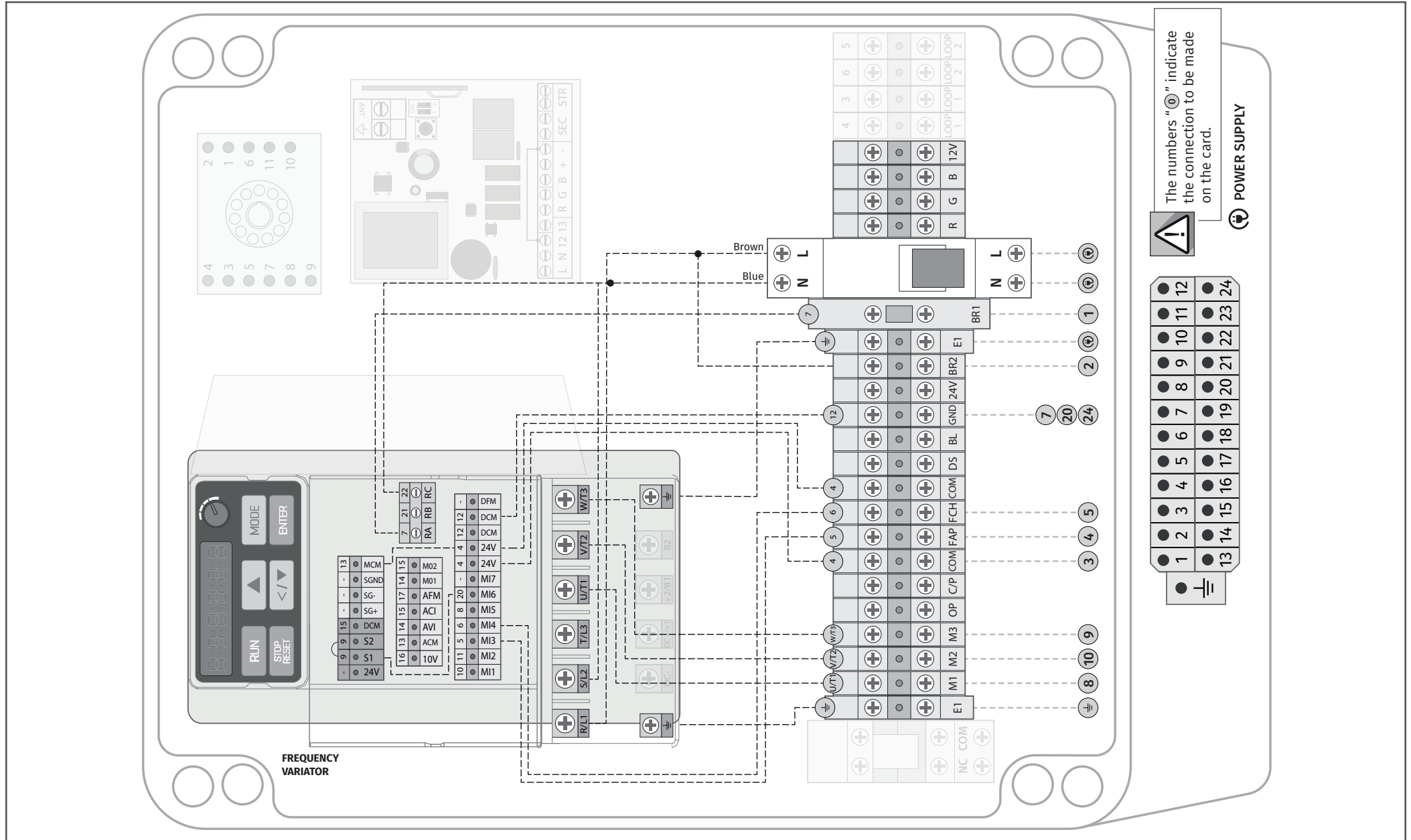

05. CONNECTIONS SQUEME

MR13 RECEIVER CONNECTIONS

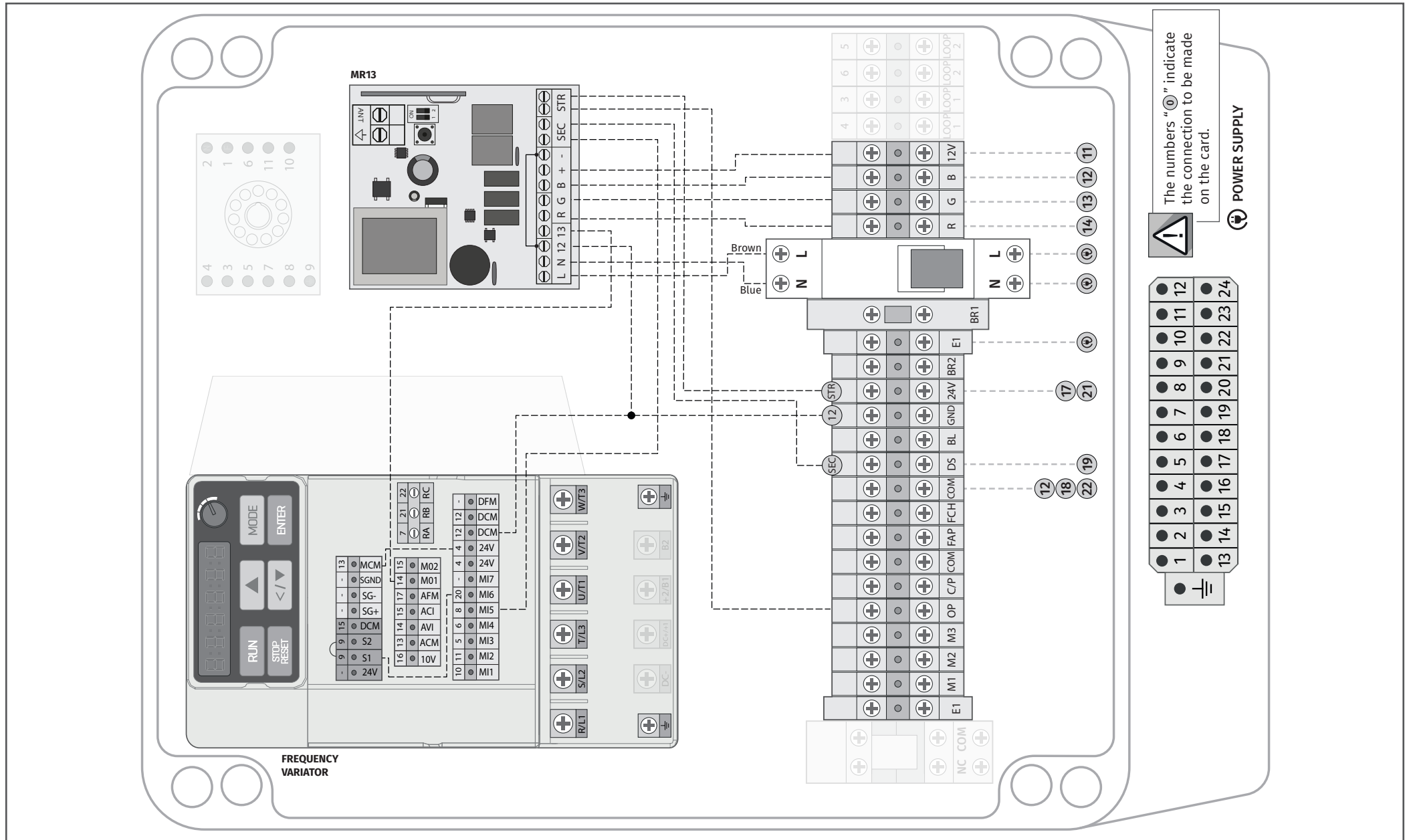

05. CONNECTIONS SQUEME

OTHER CONNECTIONS (MAGNETIC SPACER, BRAKING RESISTOR AND ENTRY PANEL)

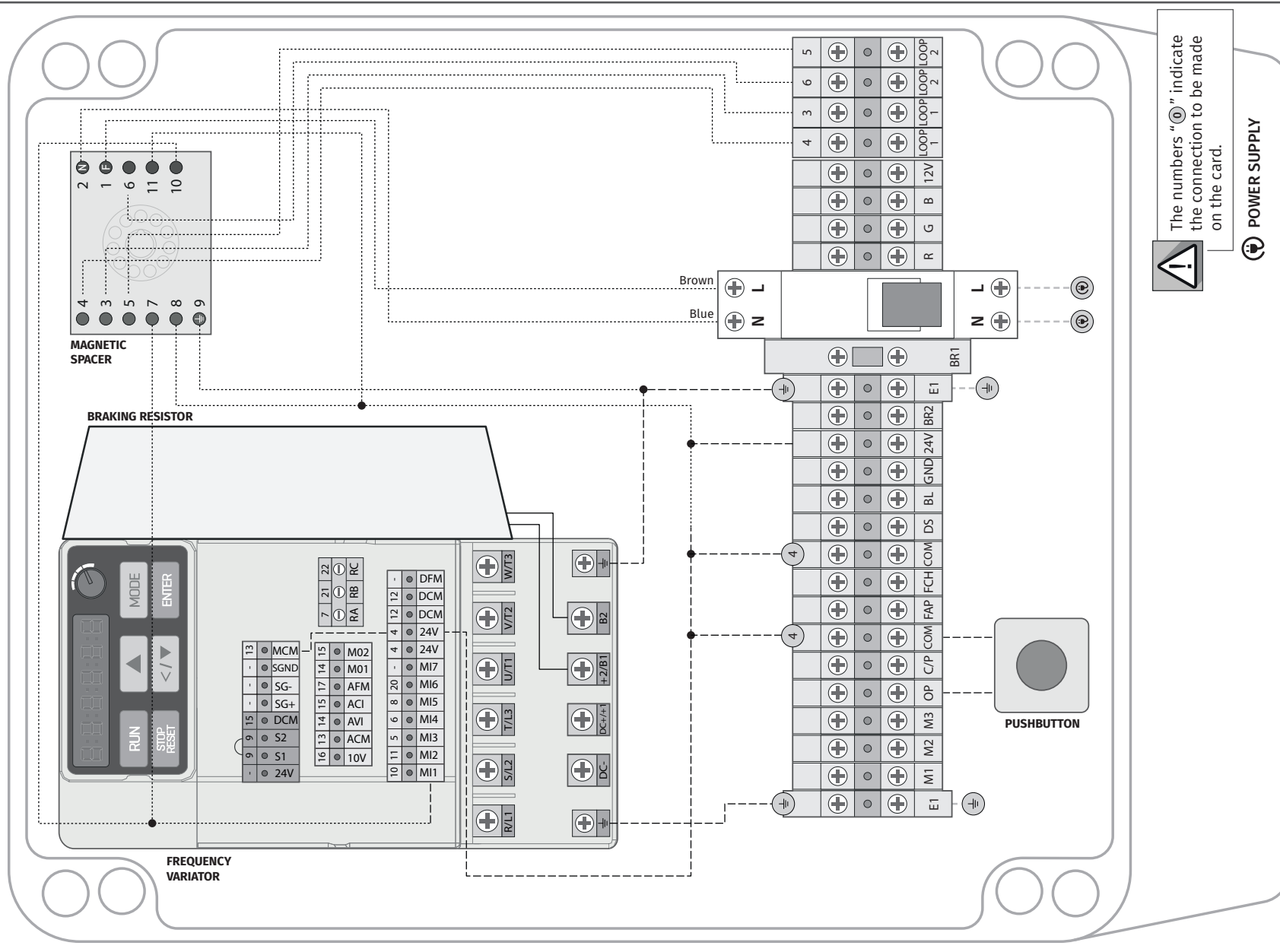

05. CONNECTIONS SQUEME

CLOSING PRE- FLASHING LIGHT

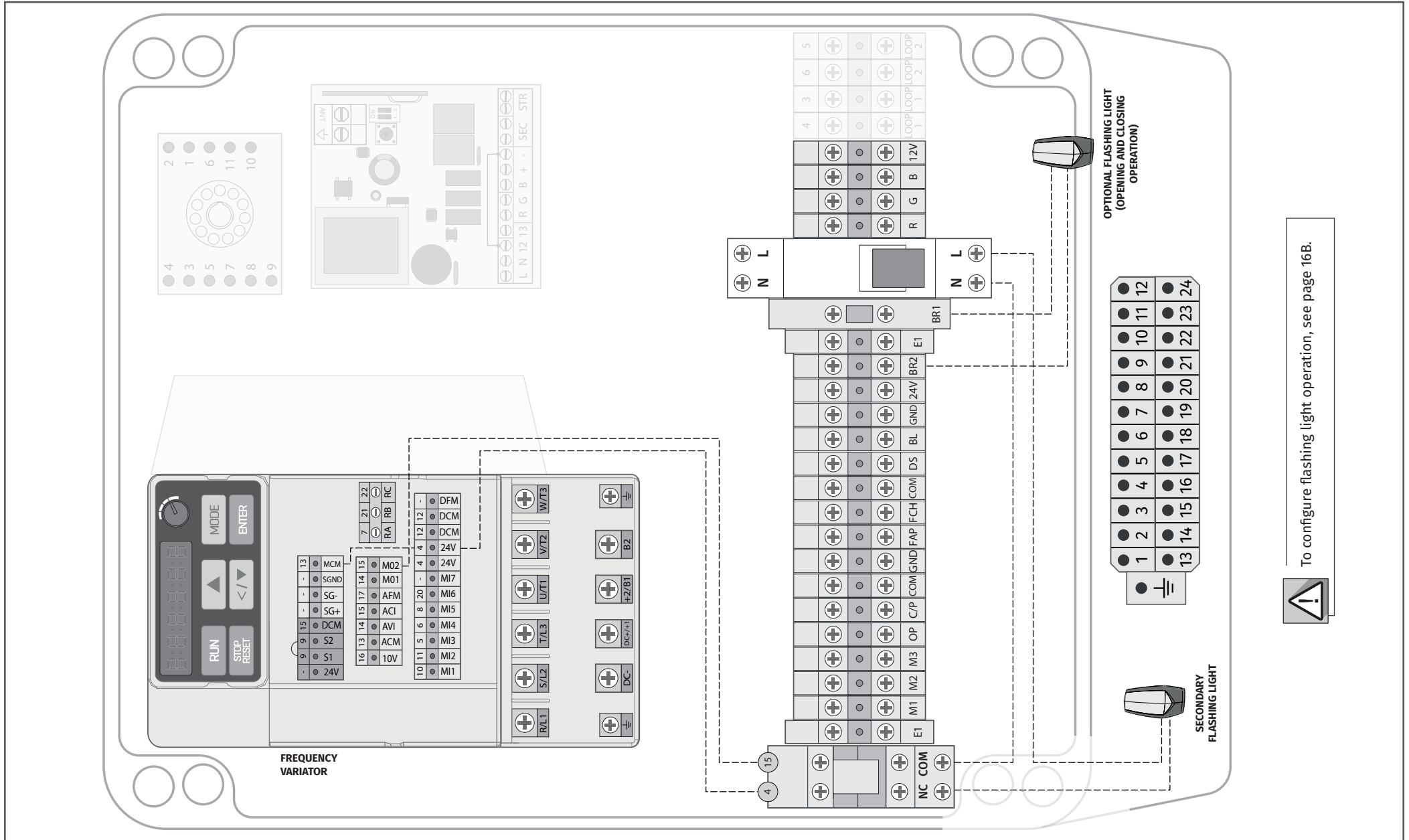

05. CONNECTIONS SQUEME

EXTERNAL COMPONENTS CONNECTIONS

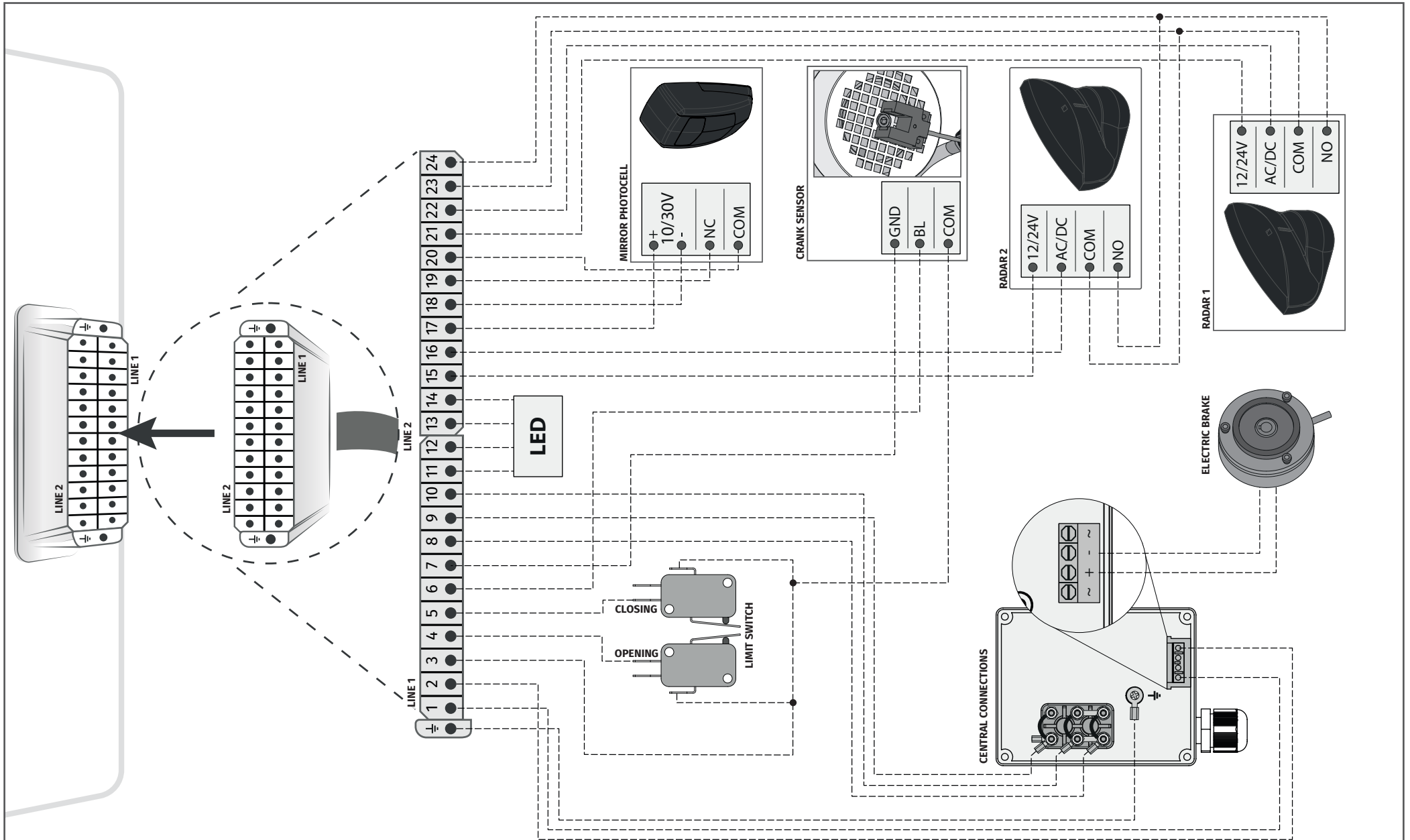

06. DESCRIPTIONS

DIGITAL NUMERIC KEYBOARD

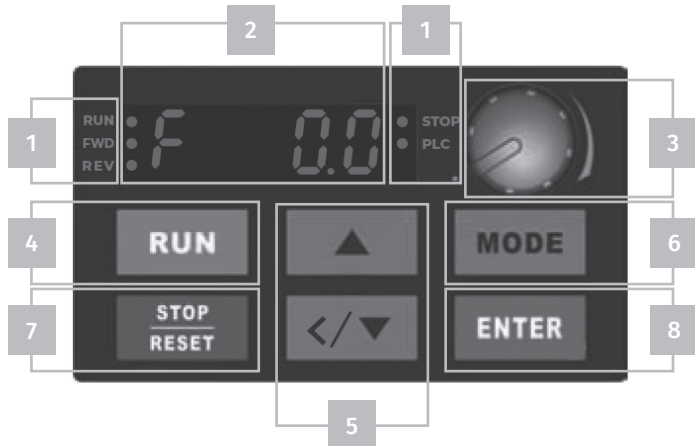

1	Status Display Shows the current state of the central	RUN	OK Variator
		FWD	Ascent Motion
		REV	Descent Motion
		STOP FLASHING	Stand By
		STOP OFF	STOP is active or door is moving
		PLC	The PLC is working
2	LED Display Indicates the frequency, voltage, current, user-defined units, etc		
5	UP and DOWN arrows Allows you to set a number of parameters and change the numeric data for a main frequency		
6	MODE Change in diferente mode views		
7	STOP/RESET Restarts the device after a failure occurs		
8	ENTER Used to enter/change programming parameters		



• 3 and 4 cannot be used.

• Only the menus on page 16A can be set by the user. **Any change made in a menu other than those mentioned on page 16A, void the warranty.** Motorline shall not be liable for damages caused if this is not observed.

06. DESCRIPTIONS

MENU NAVIGATION



1 Press **ENTER** to enter the MENU



2 Using the arrows, select one of the **SUBMENUS** referenced on page 16A.



3 Press **ENTER** to enter the SUBMENU.



4 Using the arrows to change the value



5 Press **ENTER** to confirm.



6 **End** indicates the success of the operation. **Err** indicates an operation error.



To exit MENU press "MODE" until you reach "C"

06. DESCRIPTIONS

LOCK/UNLOCK KEYBOARD

Keyboard locking is done through a password. Below are the steps for configuring and using the password.



SET PASSWORD

Enter at parameter **00.08** and set password to lock the keyboard.
The parameter value will change from 0 (disabled) to 1 (enabled)



CHANGE A PARAMETER

1 - Enter at parameter **00.07** and set password.
You will temporarily unlock the keyboard.
2 - Change the parameter you want.
The release will remain until the motor make a new operation.



WRONG PASSWORD

1 - You have **3 attempts** to enter the correct password in parameter **00.07**. LED Display indicates the number of failed attempts from 01 to 03.
Example: The wrong **first attempt** appears on the LED Display **01**.
2 - On the **4th wrong attempt** appears on the LED Display **Pcode** error message.
3 - Power off the power supply to retry 3 attempts.

RUN * STOP
FWD * PLG
REV * Pcode



SET FACTORY SETTING

1 - Enter at parameter **00.07** the code **9999** twice.
2 - Then hold the **ENTER** key for **10 seconds**.
The factory settings are restored.



DISABLE PASSWORD

1 - Enter at parameter **00.07** and enter password.
2 - Enter at parameter **00.08** and change the value from **1** to **0**.
A password será desativada.



Check page 14B for menu navigation.

06. DESCRIPTIONS

PROGRAMMING MENU ACCESS (MENU 04)



1 Press **MODE** until you find **H** function.



2 Press **ENTER** to enter on **H** function.



3 Use the arrows to find the value **04**.



4 Press **ENTER** to enter on 04



Check page 14B for menu navigation.

06. DESCRIPTIONS

PROGRAMMING MENU - 04





If the values are incorrectly adjusted, there is a risk of damage to the motor and inverter.

Parameter	Function	Settings	Factory Setting
04.00	OPEN SPEED Allows set gate opening speed.	00.00 to 70.00 Hz	50.00 to 70.00 Hz
04.01	CLOSE SPEED Allows set gate closing speed.	00.00 to 60.00 Hz	30.00 to 40.00 Hz
04.02	OPENING DECELERATION SPEED Allows to select the rate of deceleration on climbing. NOTE • The changes on deceleration opening or closing speed will change the length deceleration.	00.00 to 40.00 Hz	25.00 Hz
04.03	CLOSING DECELERATION SPEED Allows to select the rate of deceleration on climbdown. NOTE • If change the gate speed it is necessary adjust this parameter.	00.00 to 40.00 Hz	25.00 Hz
04.50	LENGHT OPENING DECELERATION Allows to set the length of deceleration. The length can be set in course programming or in the menu directly.	0 to 1000	150 (250mm)
04.51	LENGHT CLOSING DECELERATION Allows to set the length of deceleration. The length can be set in course programming or in the menu directly.	0 to 1000	150 (250mm)
04.52	PAUSE TIME Allow to set the time the gate is paused when it is open. NOTE • By set 0 seconds, the gate has no pause time.	0 = OFF 0 to 99 (ex: 99=99 sec.)	5s
04.53	PRESENTMAN This menu allows the gate to be pushed open until the limit switch is reached. In order to close the gate the user must be permanently pressing the gate down button. In this function the pedestrian button will be climbdown.	0 = Disabled 1 = ON	0 = Disabled
04.54	OP-CH/PED BUTTON LOGIC This menu allows to add 3 working modes each with their specifications.	0 = Step by step 1 = Condominium 2 = Inversion	1 = Step by step
04.55	ACCELERATION RAMP AT OPENING This menu allows you to adjust the opening acceleration ramp time to allow a smoother start of the gate.	0 to 30 (ex: 10=1 sec.)	15
04.56	ACCELERATION RAMP AT CLOSING This menu allows you to adjust the closing acceleration ramp time to allow a smoother start of the gate.	0 to 30 (ex: 10=1 sec.)	15

06. DESCRIPTIONS

PROGRAMMING MENU - 04

Parameter	Function	Settings	Factory Setting
04.57	PEDESTRIAN OPENING TIME This menu can select the length of the pedestrian opening. Knowing that 100 means 8M if put 12 means opening of a meter. If the present man is active this menu doesn't work. If set to 0 the CH/PED button will only be closed.	0 to 100	15 (aprox. 1.5m)
04.58	DECELERATION RAMP AT INVERSION Allows to set the deceleration time at inversion. Steeper or smoother stop.	0 to 20 (ex: 10=1 sec.)	10 (1 s)
04.59	HANDLING COUNT This function allows to view all complete handling performed by the operator. The menu 04.60 show the number of handling performed to the thousands while the menu 04.59 show up to hundreds of thousands (see example).	Notes: 1 Handling = 1 opening and closing cycle. Example: Menu 04.59:  Menu 04.60:  Total Handling = 20502	
04.60			
04.61	FLASHING LIGHT OUTPUT Allows to change the logic of flashing light. If it is set to 0 the flashing light will be active only when the motor is working. If select 1 the flashing light is active as long as it exits the closing limit switch, when it reaches the closing limit switch it will remain light for the time set in menu 04.63.	0 = plugged in opening and closing 1 = courtesy light	0 = opening and closing
04.62	RESET HANDLING COUNT This menu allows to reset the handling of menus 04.59 and 04.60. In order to be able to reset, will need to enter the password available only to the Motorline technical department.	Password must be entered	
04.63	COURTESY LIGHT TIME This menu allows adjust the time when the light is on, since reaching the limit switch if selected in menu 04.61.	0 to 50 Min	0
04.64	PROGRAMMATION MENU This menu has the function of placing the control board in course programming.	0 to 1	1 = control board in programming
04.65	REVERSE SLOWDOWN ADJUSTMENT This menu allows you to adjust the inversion slowdown. When the door movement is reversed, the slowdown may be higher or lower than the reference value. Therefore, with this menu you can adjust to the desired value.	0 to 1000	150

07. PROGRAMMING

SLOWDOWN ADJUSTMENT

Slowing down is a reduction in the door's movement speed until it reaches the limit switch.
To adjust the slowdown at opening and closing the door, follow these steps in the following order:





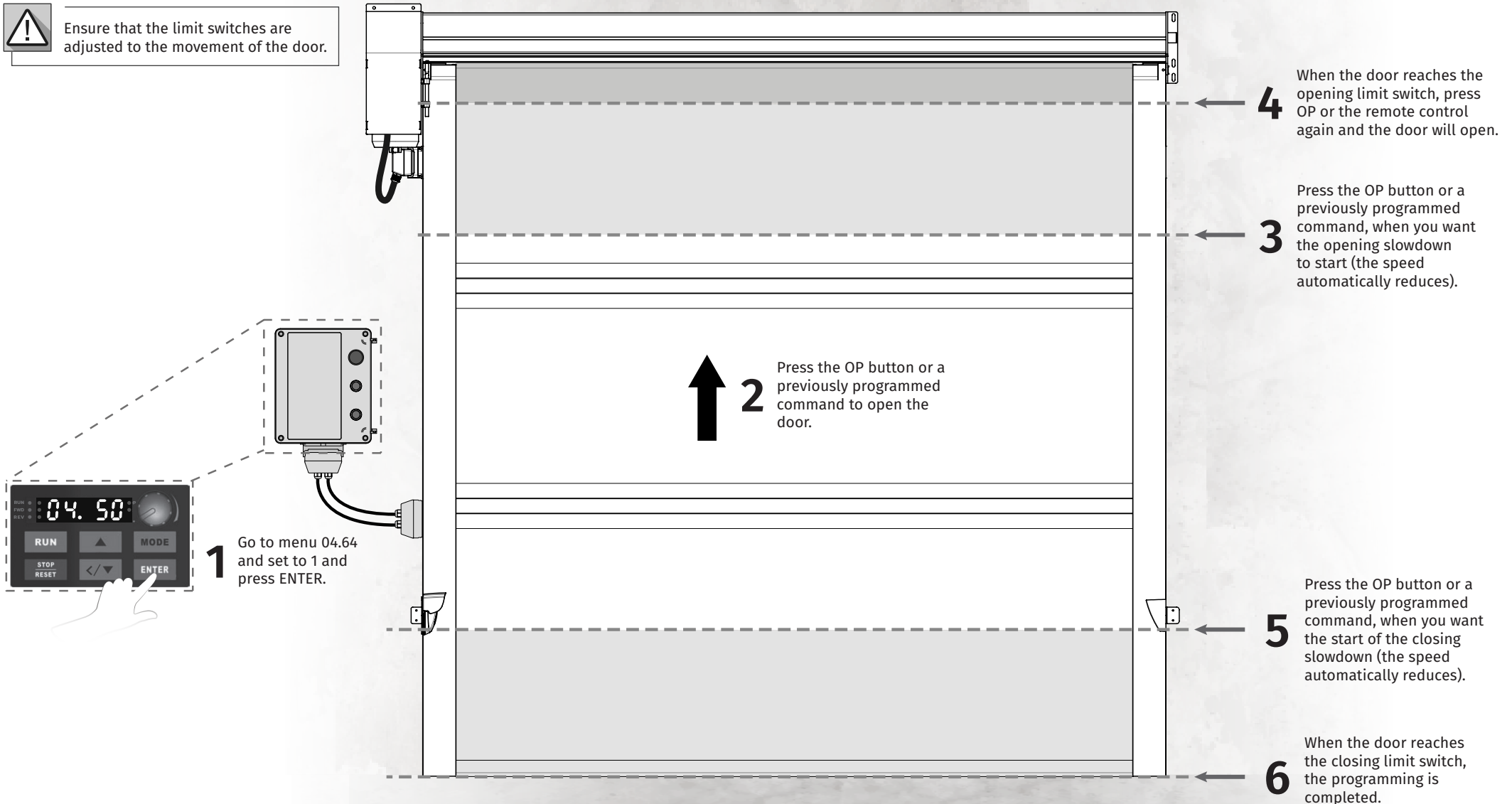









Ensure that the limit switches are adjusted to the movement of the door.









07. PROGRAMMING

LED DISPLAY MESSAGES

Message displayed	Description
 F600	Displays the master frequency of the AC variator.
 H500	Displays the effective output frequency at the U / T1, V / T2, and W / T3 terminals.
 A 50	Displays the output current at the U / T1, V / T2, and W / T3 terminals.
 Frd	Opening Door - Displays the opening operation status on the AC variator.
 rEu	Closing Door - Displays the closing operation status on the AC variator.
 c 00	Entry indications. This indication is displayed whenever there is no common input or the PLC1 parameter is in PLC0.
 PLC1	Mandatory mode for operatuib (do not change this menu)
 EF	External fault
 End	Displays "End" for approximately 1 second if the input is accepted by pressing the ENTER key. After a value is set in the parameter, the new value is automatically added to the memory. To modify an entry, use the  and  keys.
 Err	Displays "Err" if the input is invalid.
 Sto	STOP enable the crank sensor
C111	Limit switch enabled and opening key pressed.
C222	Limit switch enabled and closing key pressed.
C333	Disabled
C444	Opening limit switch enabled and decline key pressed
C555	Closing limit switch enabled and closing key pressed
C666	Opening limit switch enabled and climbing key pressed
C777	Closing limit switch enabled and climbing key pressed
C888	Photocells enabled.
C999	Emergency stop, STO or crank sensor.
C800	No connection/limit switches and safety.

08. TROUBLESHOOTING

INSTRUCTIONS FOR CONSUMERS AND SPECIALIZED TECHNICIANS

Fault identification	Description of failure	Corrections
 OC	OVERCURRENT Abnormal increase of current.	<ul style="list-style-type: none"> 01 • Check if the motor power corresponds to the output power of the AC motor variator. 02 • Check for possible short circuits on U / T1, V / T2, W / T3 wiring connections. 03 • Check for possible short circuits in the wire connections between the AC motor variator and the motor and ground wire. 04 • Check for loose contacts between the AC motor variator and the motor. 05 • Check for possible overload conditions on the motor. 06 • After a short circuit, if there are still anomalies in the operation of the AC motor variator, you must send the product to the manufacturer.
 OV	OVERVOLTAGE The DC voltage has exceeded the maximum allowed value.	<ul style="list-style-type: none"> 01 • Check if the input voltage of the AC motor variator is within the rated voltage class. 02 • Check for possible voltage variations. 03 • Check if the power required for the brake is within the specified limits.
 LV	LOW VOLTAGE The AC motor variator detects that the DC terminal voltage is below the minimum value.	<ul style="list-style-type: none"> 01 • Check if the input voltage of the AC motor variator is within the rated voltage class. 02 • Check if motor for abnormal load. 03 • Check if the input power connections are correct with R-S-T (for 3-phase models) without losing the phase.
 OL	OVERLOAD The AC variator detects excessive current at the control output.	<ul style="list-style-type: none"> 01 • Check if the motor is overloaded. 02 • Use the following model with AC motor variator power.
 oca	OVERLOAD DURING ACCELERATION	<ul style="list-style-type: none"> 01 • Short-circuit at the motor output: Check that the isolation on the output lines is in good condition. 02 • Acceleration time too short: Increase the acceleration time.
 ocd	OVERCURRENT DURING RELEASE	<ul style="list-style-type: none"> 01 • Short-circuit at the motor output: Check that the isolation on the output lines is in good condition.
 ot 1	DETECTION OF EFFORT AND EXCESS OF CONSUMPTION	<ul style="list-style-type: none"> 01 • Check parameter 06.04 and set lower sensitivity (set a value closer to 200%). 02 • Check if the door is stucked at some point.