

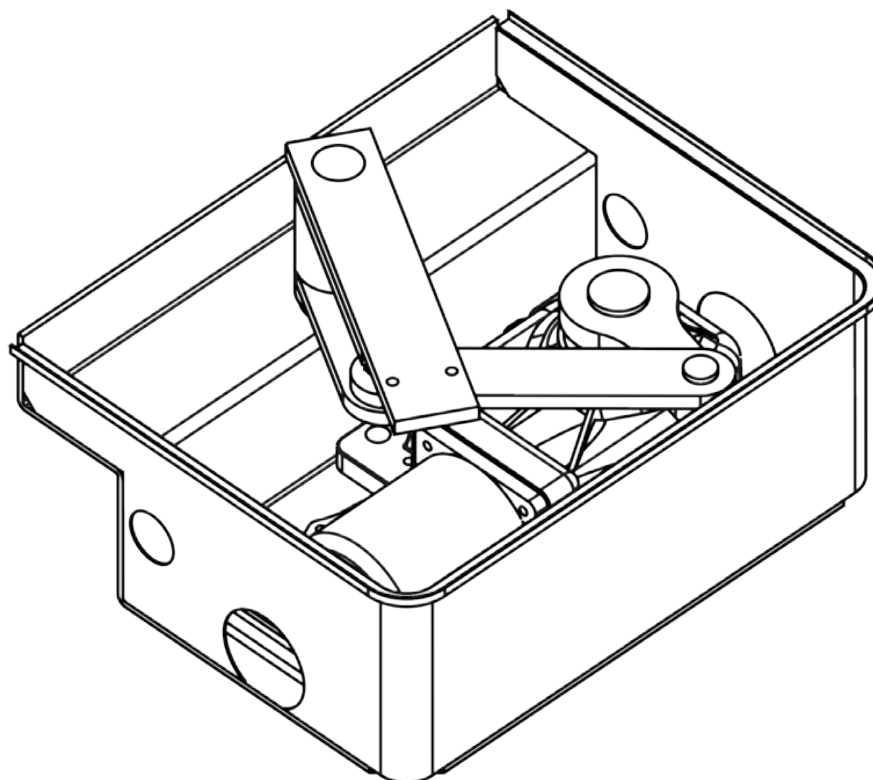

SUBWING 700

USER'S AND INSTALLER'S MANUAL



00. CONTENT

INDEX

01. SAFETY INSTRUCTIONS

STANDARDS TO FOLLOW 1B

02. OPERATOR

CONNECTION SCHEME 2A

INSTALLATION MAP 2A

TECHNICAL SPECIFICATIONS 2B

DIMENSIONS 2B

03. INSTALLATION

GATE WING OPENING ANGLE 3A

BOX INSTALLATION 3B

ASSEMBLING THE OPERATOR AND LEVERS 4A

FASTENING THE OPERATOR LEVER TO THE GATE 4B

EMERGENCY RELEASE PROCEDURE 5A

LIMIT SWITCHES ASSEMBLY (OPTIONAL) 5A





04. TROUBLESHOOTING

FINAL CONSUMERS AND SPECIALIZED INSTALLERS INSTRUCTIONS 5B

01. SAFETY INSTRUCTIONS

STANDARDS TO FOLLOW

ATTENTION:

	This product is certified in accordance with European Community (EC) safety standards.
	This product complies with Directive 2011/65/EU of the European Parliament and of the Council, of 8 June 2011, on the restriction of the use of certain hazardous substances in electrical and electronic equipment.
	(Applicable in countries with recycling systems). This marking on the product or literature indicates that the product and electronic accessories (eg. Charger, USB cable, electronic material, controls, etc.) should not be disposed of as other household waste at the end of its useful life. To avoid possible harm to the environment or human health resulting from the uncontrolled disposal of waste, separate these items from other types of waste and recycle them responsibly to promote the sustainable reuse of material resources. Home users should contact the dealer where they purchased this product or the National Environment Agency for details on where and how they can take these items for environmentally safe recycling. Business users should contact their vendor and check the terms and conditions of the purchase agreement. This product and its electronic accessories should not be mixed with other commercial waste.
	This marking indicates that the product and electronic accessories (eg. charger, USB cable, electronic material, controls, etc.) are susceptible to electric shock by direct or indirect contact with electricity. Be cautious when handling the product and observe all safety procedures in this manual.

- It is important for your safety that these instructions are followed.
- Keep these instructions in a safe place for future reference.
- The **ELECTROCELOS S.A.** is not responsible for the improper use of the product, or other use than that for which it was designed.
- The **ELECTROCELOS S.A.** is not responsible if safety standards were not taken into account when installing the equipment, or for any deformation that may occur.
- The **ELECTROCELOS S.A.** is not responsible for insecurity and malfunction of the product when used with components that were not sold by the them.
- This product was designed and manufactured strictly for the use indicated in this manual.
- Any other use not expressly indicated may damage the product and/or can cause physical and property damages, and will void the warranty.
- Do not make any changes to the automation components and/or their accessories.
- Keep remote controls away from children, to prevent the automated system from being activated involuntarily.
- The customer shall not, under any circumstances, attempt to repair or tune the automatism. Must call qualified technician only.
- The installer must have certified professional knowledge at the level of mechanical assemblies in doors and gates and control board programming. He should also be able to perform electrical connections in compliance with all applicable regulations.
- The installer should inform the customer how to handle the product in an emergency and provide him the manual.

02. OPERATOR

CONNECTION SCHEME

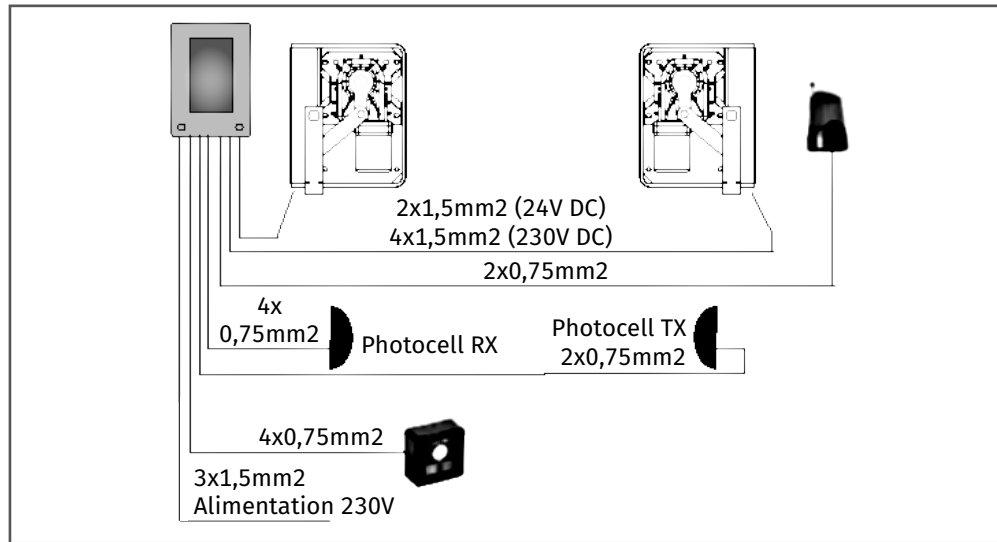

INSTALLATION MAP

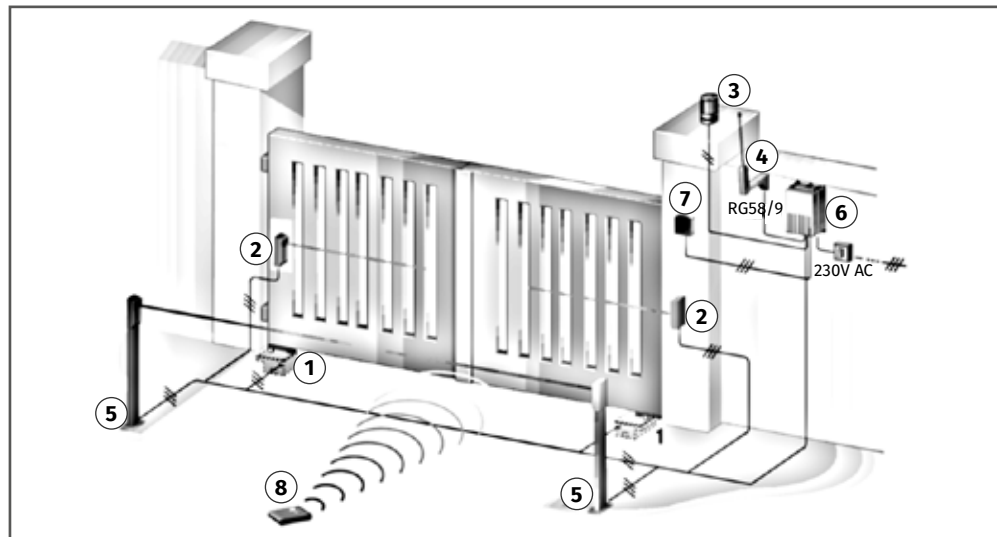

- 1 • Motor 3 • Flashing warning light 5 • Internal photocell 7 • Key-switch
2 • External photocell 4 • Antenna 6 • Electronic control unit 8 • Remote control

02. OPERATOR

TECHNICAL SPECIFICATIONS

	24V	230V
• Max. weight of gate	500Kg	
• Max. width of gate	2,50m	
• Motors power supply	24V DC	230V AC
• Motor power	50W	280W
• Motor RPM	1800	1400
• Condenser	-	12,5µF
• Mechanical unlock for emergency	With key	
• Working temperature	-25°C/+55°C	
• Weight	10Kg	
• Protection	IP67	
• Opening time 90°	16 sec	
• Force of thrust	250Nm	
• Motor current input	3A	1,5A

DIMENSIONS

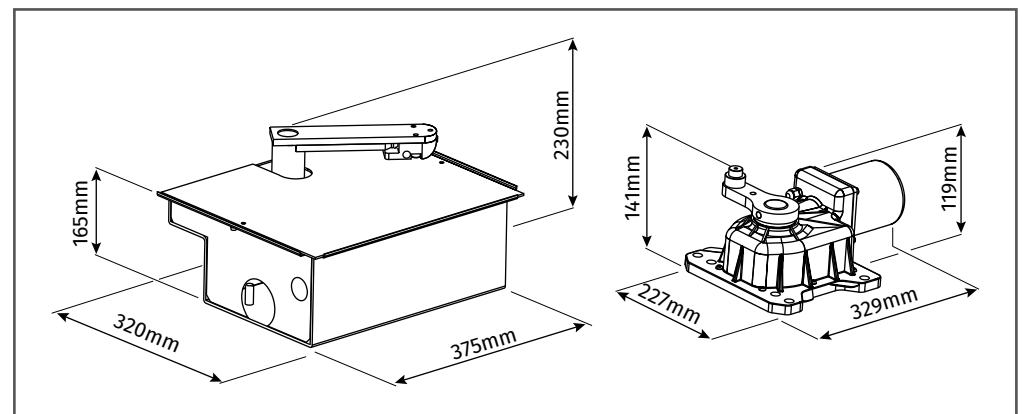

03. INSTALLATION

GATE WING OPENING ANGLE

Establish the required opening angle.

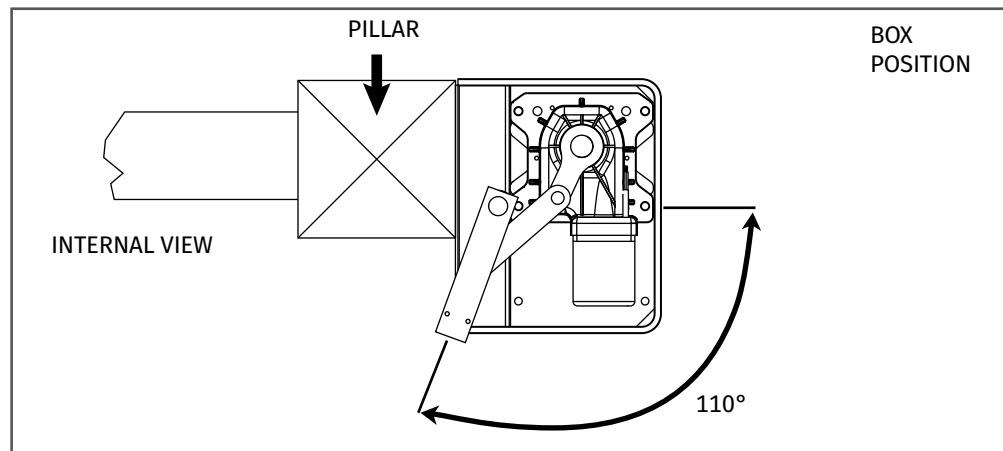
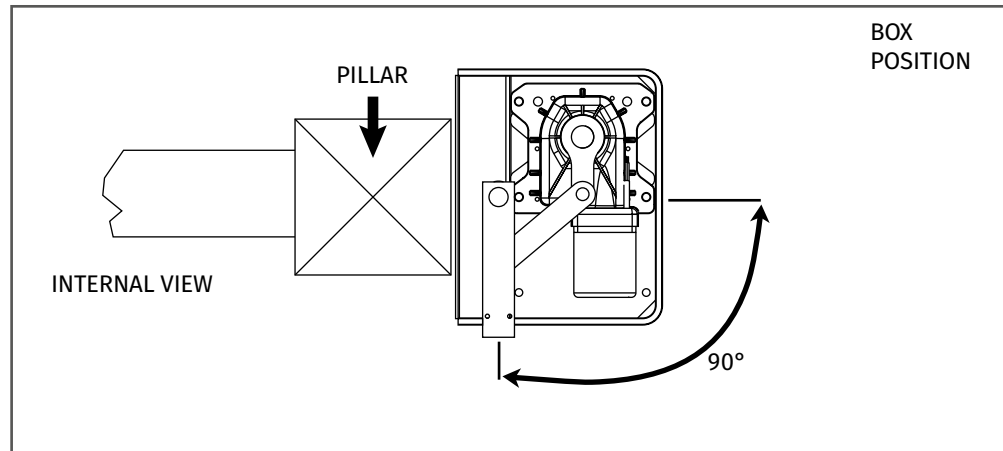

03. INSTALLATION

BOX INSTALLATION

1 • Dig a hole big enough to hold the box containing the operator (C1).

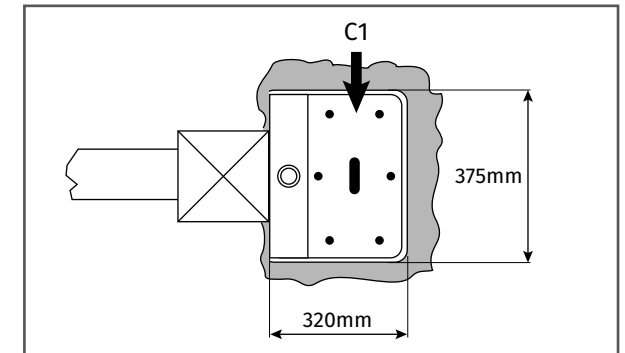

2 • Insert the tube for water drainage in the prepared hole (F1).

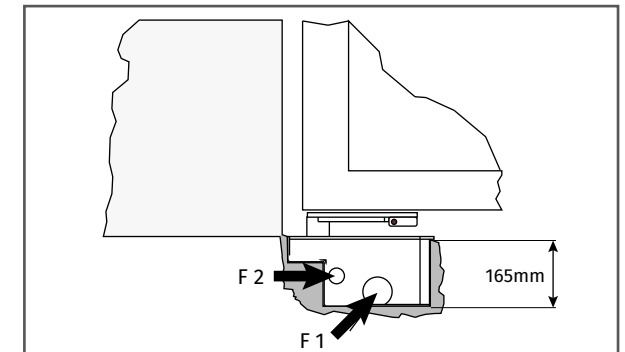

3 • Insert the sheath for laying the power cables (F2).

Note: while positioning the box, keep in mind the minimum distance there must be between the pillar and the centre of rotation of the gate hinge.

4 • Cement so that the box cannot be moved, wait for it to dry and then assemble the operator and levers.

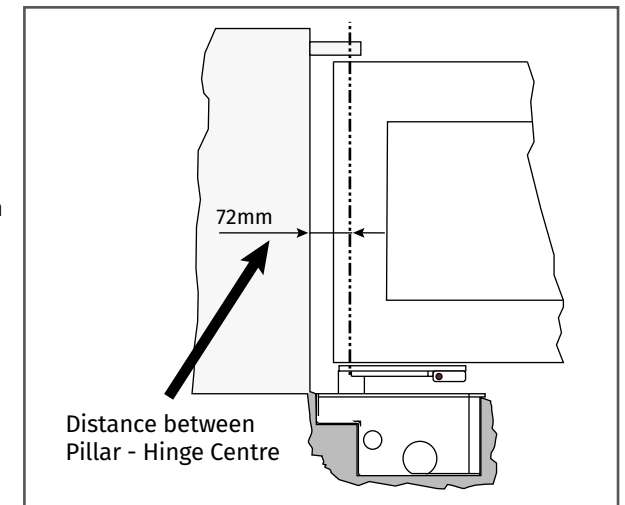

03. INSTALLATION

ASSEMBLING THE OPERATOR AND LEVERS

1 • Insert the motor into the foundation case and fix it with nuts and washers supplied.

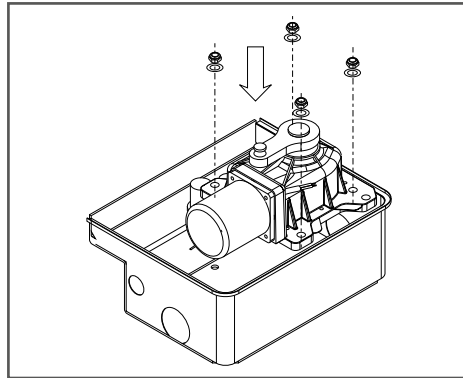

2 • Insert the ball in the pin located on the box and fit the gate anchorage lever (L1).

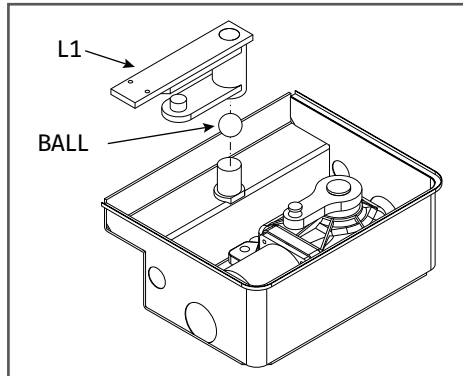

3 • Put the connection lever (L2) between the levers (L3) and (L1) and block it with screws and washers supplied.

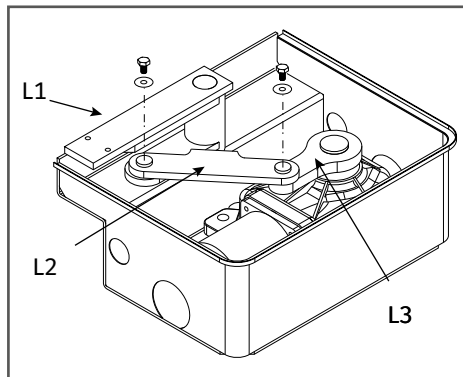

03. INSTALLATION

FASTENING THE OPERATOR LEVER TO THE GATE

Insert the cover and fasten it with the screws provided Position.

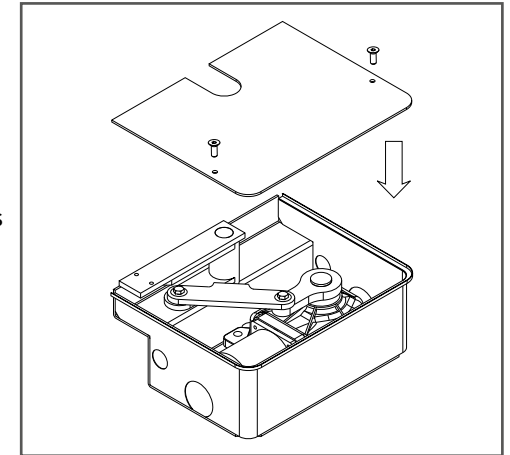

Position the gate wing and the lever (L1) so that they are perfectly aligned and fasten them by welding or similar.

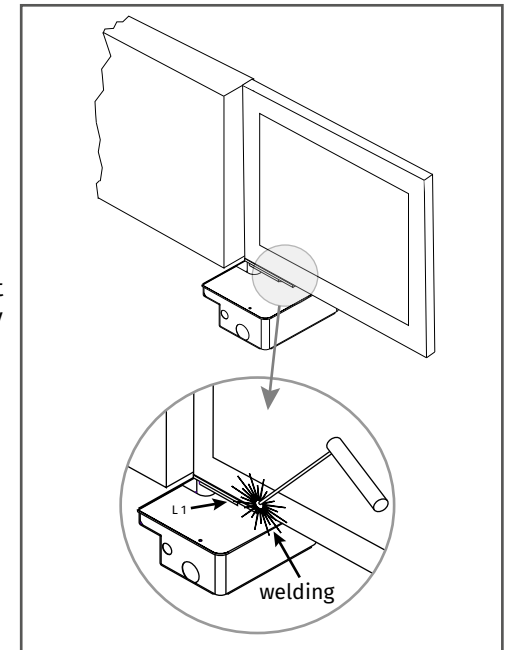

03. INSTALLATION

EMERGENCY RELEASE PROCEDURE

Insert the key C provided into the appropriate hole on the lever L1 and turn the key.

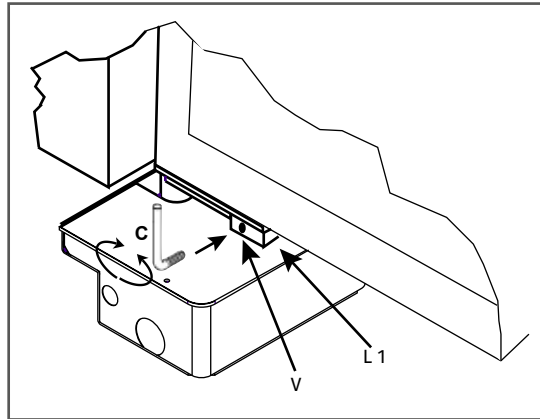

LIMIT SWITCHES ASSEMBLY (OPTIONAL)

Insert, regulate and block the mechanical limit switches in the desired position.

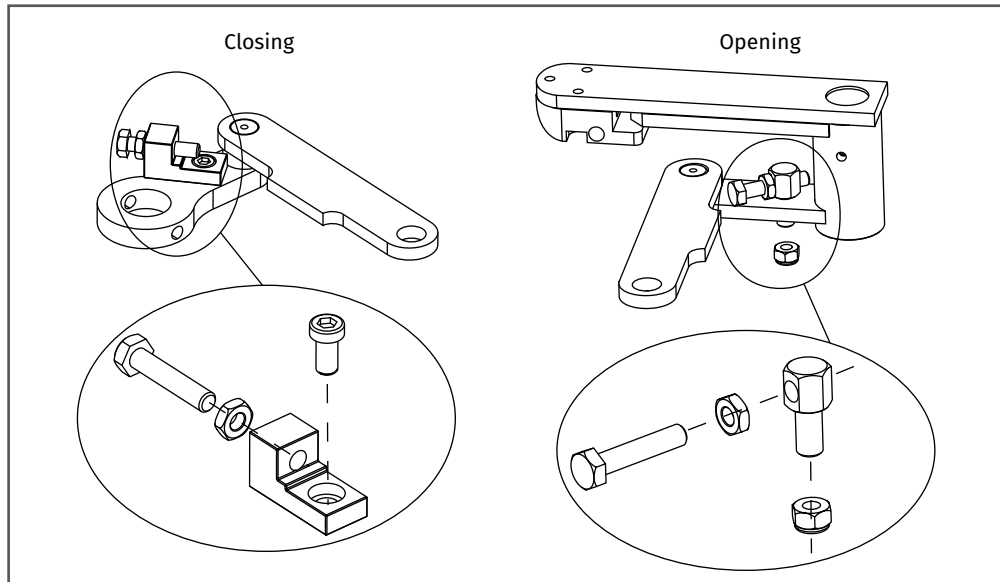

04. TROUBLESHOOTING

FINAL CONSUMERS AND SPECIALIZED INSTALLERS INSTRUCTIONS

Problem	Probable cause	Solution
	<ul style="list-style-type: none"> • 230V mains voltage absent 	<ul style="list-style-type: none"> • Check master switch
	<ul style="list-style-type: none"> • Emergency STOP present 	<ul style="list-style-type: none"> • Check for any STOP selectors or commands. If not used, check jumper on STOP contact input on the control board
<ul style="list-style-type: none"> • On giving a command with the remote control or with the key-switch, the gate doesn't open or the motor doesn't start 	<ul style="list-style-type: none"> • Fuse blown 	<ul style="list-style-type: none"> • Replace with one of same value.
	<ul style="list-style-type: none"> • Power cable of motor or motors not connected or faulty 	<ul style="list-style-type: none"> • Connect the cable to appropriate terminal or replace.
	<ul style="list-style-type: none"> • The photocell is not functioning or the beam is interrupted 	<ul style="list-style-type: none"> • Check the connection, remove any obstacle across the beam
<ul style="list-style-type: none"> • On giving a command with the remote control, the gate doesn't open but works with the key command 	<ul style="list-style-type: none"> • The remote control has not been memorised or the battery is flat 	<ul style="list-style-type: none"> • Carry out the remote control learning procedure on the radio receiver or replace the battery with a new one
<ul style="list-style-type: none"> • The gate starts, but stops immediately 	<ul style="list-style-type: none"> • The force of the motor or motors is insufficient 	<ul style="list-style-type: none"> • Modify the value with the FORCE trimmer on the control unit
<ul style="list-style-type: none"> • One wing opens and the other closes 	<ul style="list-style-type: none"> • The connection is not correct 	<ul style="list-style-type: none"> • Invert the connection of the cable of the motor which rotates in the wrong sense